

Alpha

Il primo forno elettrico a platea rotante.

The first electric oven with rotating cooking plate.
Der erste Elektro-Ofen mit rotierender Platte.



Alpha



CUPPONE
YOUR PARTNER IN BAKING SINCE 1963

Alpha: precisione e flessibilità in un unico forno.

La platea rotante di Alpha, regolabile in velocità e direzione, garantisce una cottura uniforme e perfetta. Le temperature differenziate del cielo e della platea ti permettono di personalizzare ulteriormente il processo di cottura. Un forno professionale progettato per soddisfare le esigenze dei pizzaioli più esigenti.



Alpha: Precision and flexibility in one.

Alpha's rotary bed plate can be adjusted in speed and direction, thus guaranteeing uniform and perfect baking results. Highly customized baking processes are allowed by differentiated temperatures of top element and bed plate. A professional oven designed to meet the needs of the most demanding pizza chefs.

Alpha: Präzision und Flexibilität in einem einzigen Ofen.

Die in Geschwindigkeit und Richtung einstellbare Drehplatte von Alpha sorgt für gleichmäßiges und perfektes Backen. Dank der unterschiedlichen Temperaturen von Ober- und Unterhitze können Sie den Backvorgang noch individueller gestalten. Ein professioneller Ofen, der den Anforderungen der anspruchsvollsten Pizzabäcker gerecht wird.



Caratteristiche speciali | Special features | Besondere Merkmale



Sistema di controllo touch screen
Touch screen control system
Touchscreen Kontrollsystem

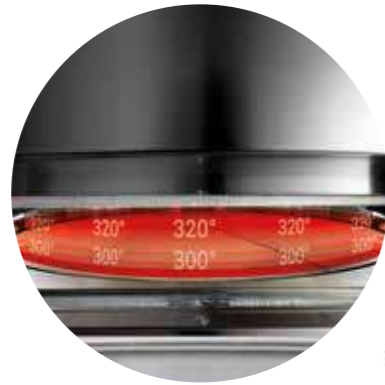

Temperatura differenziata cielo/platea
Differentiated ceiling and floor temperature
Differenzierte Ober- und Unterhitze



Controllo direzione e velocità di rotazione piano cottura
Control of the direction and the speed of the cooking plate rotation
Kontrolle der Drehrichtung und Geschwindigkeit der Backfläche



Guarnizione di tenuta calore tra porta e camera di cottura
Heat seal between door and cooking chamber
Wärmeabdichtung zwischen Tür und Backkammer



Resistenze differenziate cielo-platea
Top/Floor differentiated heating elements
Ober- und Unterhitze Résistances haut



Dotazioni Optional | Optional Equipment | Zubehör

Kit napoli (pietre 25mm)
Napoli kit (25mm stones)
Kit napoli (25mm steine)

Collegamento a Cloud Cuppone
Cuppone Cloud connection
Cuppone Cloud-Verbindung

Resistenze potenziate
Boosted heating elements
Verstärkte heizwiderstände

A/PPDX Portapale
Peel holder
Schaufelhalter

Tecnologie che fanno la differenza | Technologies that make the difference | Technologien, die den Unterschied machen



Vetro panoramico singolo+ vetro temperato di protezione calore removibile
Single, high-visibility glass pane + removable heat-protection tempered glass
Einfaches Sichtfenster, abnehmbares + gehärtetes Hitzeschutzglas



Apertura e chiusura con molla a compressione
Opening and closing system with compression spring
Öffnungs- und Schließsystem mit Druckfeder



Guarnizione tenuta calore tra porta e camera di cottura
Heat seal between door and cooking chamber
Wärmeabdichtung zwischen Tür und Backkammer



Resistenze differenziate cielo-platea
Top/Floor differentiated heating elements
Ober- und Unterhitze



Recupero veloce integrato
Fast recovery function
Wärmerückgewinnung Funktion



Funzione economy
Economy functions
Economy Funktion



Programmazione cottura
Cooking programming
Programmierung der Backzeit



Sistema di controllo touch screen
Touch screen control system
Touchscreen Kontrollsystem



Timer
Timer
Timer



Costruzione in acciaio inox
Stainless steel construction
Konstruktion aus Edelstahl



Isolamento in lana di roccia
Evaporated rock wool insulation
Isolierung aus verdampfter Steinwolle



Ventola di raffreddamento
Cooling fans
Kühlventilator



Pirolisi
Pyrolysis
Pyrolysis



Sfiato vapori di cottura regolabile
Adjustable steam vents
Regulierbarer Abzug der Backdämpfe



Piano di cottura in mattoni di cordierite
Cordierite stone cooking floor
Backfläche aus Cordierit



Platea rotante: flessibilità per ogni esigenza.

La nostra platea rotante ti offre **massima flessibilità**, con doppio senso di rotazione programmabile e due velocità personalizzabili. Scegli il **ritmo di cottura** ideale per una resa uniforme e impeccabile.

Rotary bed plate: Flexibility for any need.

Our rotary bed plate offers extreme flexibility, with two programmable directions and two-speed personalization. Choose the perfect baking pace for a uniform and flawless results.

Drehbare Platte: Flexibilität für jeden Bedarf.

Unsere drehbare Platte bietet Ihnen maximale Flexibilität mit zwei programmierbaren Drehrichtungen und zwei individuell einstellbaren Geschwindigkeiten. Wählen Sie den idealen Garrhythmus für ein gleichmäßiges und makellooses Ergebnis.



Controllo totale, risparmio garantito.

Pianifica la tua settimana, mese o anno con la **programmazione avanzata**. Con il nostro programma Eco, riduci il consumo energetico durante i periodi di standby. Il sistema può avvisarti in tempo reale se superi la soglia impostata, aiutandoti a gestire meglio i consumi. Grazie al cloud puoi tenere monitorato il tuo forno. Alpha è **flessibilità, efficienza e controllo**.



Complete control and guaranteed savings.

Plan your week, month or year with **advanced scheduling**. Reduce energy consumption during stand-by periods, using our Eco program. The system can send real-time warnings when the set threshold is exceeded, thus helping you to manage consumptions better. Thanks to the cloud service, you can keep an eye on your oven. Alpha means **flexibility, efficiency and control**.

Volle Kontrolle, garantierte Einsparungen.

Planen Sie Ihre Woche, Ihren Monat oder Ihr Jahr mit der **erweiterten Programmierung**. Mit unserem Eco-Programm können Sie den Energieverbrauch während der Standby-Phasen reduzieren. Das System kann Sie in Echtzeit warnen, wenn Sie den eingestellten Grenzwert überschreiten, und hilft Ihnen so, Ihren Verbrauch besser zu steuern. Dank der Cloud können Sie Ihren Ofen im Auge behalten. Alpha ist **Flexibilität, Effizienz und Kontrolle**.

Design al servizio della cottura.

Il nostro nuovo forno professionale è stato progettato per soddisfare le necessità dei pizzaioli più esigenti. Le luci LED di ultima generazione offrono una luminosità senza precedenti, mentre il **nuovo vetro porta** permette un **controllo visivo ottimale** della cottura. Realizzato in acciaio e con una seconda **facciata rivestita**, Alpha garantisce un'eccellente isolamento termico. Le linee innovative e il **design più squadrato** rendono questo forno un prodotto unico nel suo genere.

Design dedicated to baking.

Our new professional oven was designed to meet the needs of very demanding pizza chefs. New-generation LED lights offer unprecedented lighting, while the new glass pane allows enhanced visual control over the baking process through the door. Being made of steel and featuring a secondary coated face, Alpha ensures excellent thermal insulation. Innovative lines and a sharper design make this oven a unique product.

Design im Zeichen eines optimalen Garprozesses.

Unser neuer Profi-Backofen wurde entwickelt, um die Anforderungen der anspruchsvollsten Pizzabäcker zu erfüllen. Die neuesten LED-Leuchten bieten eine noch nie dagewesene Helligkeit, während die neue Glastür eine optimale Sichtkontrolle des Garvorgangs ermöglicht. Der aus Stahl gefertigte und mit einer zweiten Beschichtung versehene Alpha bietet eine hervorragende Wärmedämmung. Die innovativen Linien und das eckigere Design machen diesen Ofen zu einem einzigartigen Produkt.



Eleganza ampliata: cattura i fumi con stile.

La nuova cappa, più grande e performante, offre un'aspirazione in grado di catturare una quantità superiore di fumi e vapori. Ideale per ambienti di lavoro intensivi, mantiene l'aria pulita, migliorando il comfort e la qualità del tuo spazio di cottura.

Expanded elegance: capturing fumes with style.

The new hood is larger and offers enhanced performance, allowing to capture more fumes and vapors. Ideal for intensive-use environments, this hood keeps the air clean and improves comfort and quality in the cooking area.

Mehr Eleganz: Dunstabzugshaube mit Stil

Die neue, größere und leistungsstarke Haube bietet eine Absaugung, die mehr Rauch und Dämpfe auffängt. Sie ist ideal für intensive Arbeitsumgebungen, hält die Luft sauber und verbessert den Komfort und die Qualität Ihres Kochbereichs.

Alpha porta la pizza ovunque grazie al suo supporto speciale.

Progettato per essere trasportato facilmente e permettere il passaggio attraverso porte di soli 80cm di larghezza, il forno è posizionabile con semplicità in ogni punto del tuo laboratorio. La struttura robusta e i materiali di alta qualità garantiscono prestazioni eccellenti e di lunga durata.

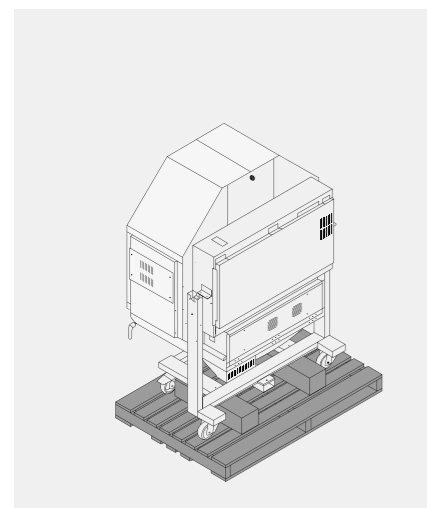
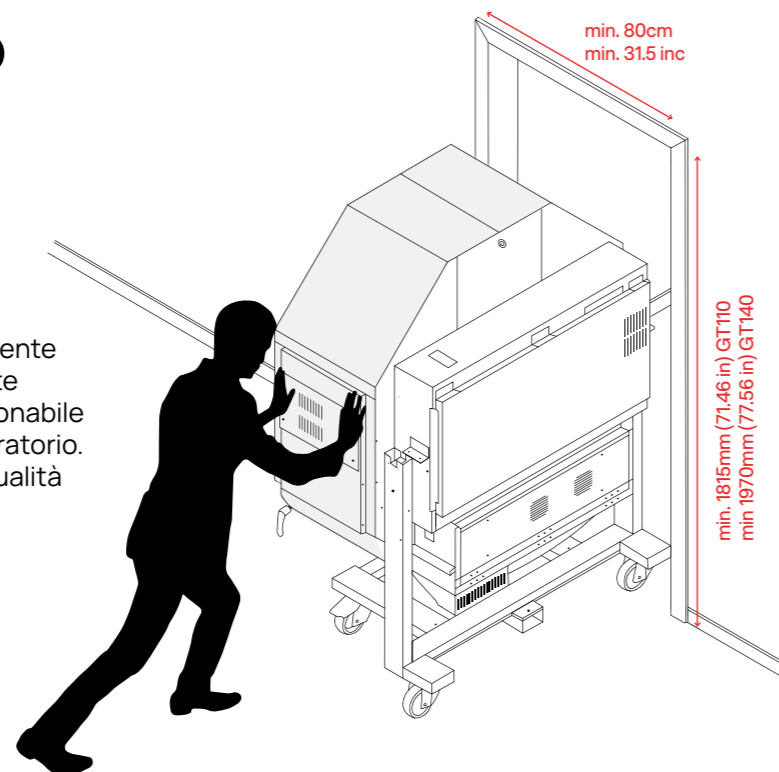

a.
Il forno arriva montato già sul suo supporto pronto per l'installazione.

The oven is supplied already assembled to its stand, ready for installation.

Der Ofen wird einbaufertig auf seinem Untergestell montiert geliefert.

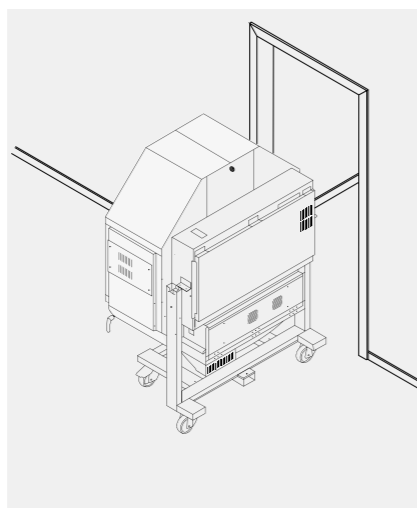

b.
Il forno, posizionato sulla sua base mobile dotata di ruote, può passare attraverso porte di dimensioni standard.

The oven placed on its movable, wheeled stand can pass through standard-width doors.

Auf seinem mobilen Sockel mit Rädern passt der Ofen durch Türen in Standardgröße.

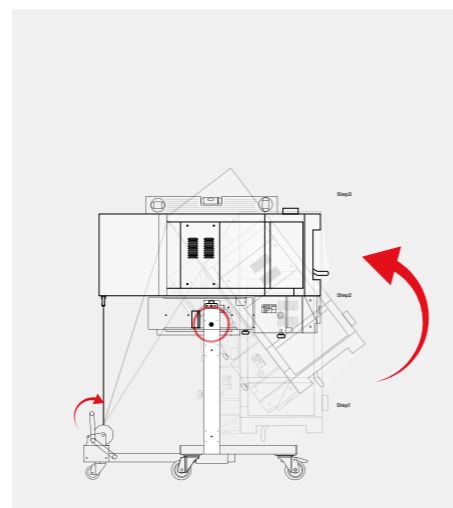

c.
Grazie al sistema di rotazione a carrucola la camera di cottura raggiunge facilmente la posizione di utilizzo.

Thanks to its pulley-operated rotary system, the baking chamber is easily taken to its position for use.

Dank des Rotationssystems mit Umlenkrollen erreicht die Backkammer leicht ihre Einsatzposition.

Alpha's special stand can bring pizza anywhere.

It was specifically designed to allow to pass through 80cm-wide doors, so that you can easily place the oven in any corner of your kitchen. Robust structure and high-quality materials ensure excellent performance over time.

Dank des speziellen Untergestells kann der Alpha die Pizza überall backen.

Der Ofen ist so konzipiert, dass er leicht transportiert werden kann und durch Türen mit einer Breite von nur 80 cm passt. Die robuste Konstruktion und die hochwertigen Materialien garantieren eine hervorragende Leistung und eine lange Lebensdauer.



Guarda il video di montaggio di Alpha
Watch the video on how to assemble Alpha
Sehen Sie sich das Alpha-Montagevideo an



Forno elettrico monocamera a platea rotante
Single chamber electric oven with rotating cooking plate
Einkammer-Elektro-Pizzaofen mit drehbarer Backplatte



MODELLO - MODEL - MODELL		AO110/1TS	AO140/1TS
Dimensioni esterne External dimensions Außenmaße	L mm	1388	1688
	P mm	1438	1738
	H mm	1697	1697
H 180 mm			
Diametro camera di cottura Cooking chamber diameter Durchmesser der Backkammer	Ø mm	1100	1400
Dimensioni porta Door dimensions Maße der Tür	L mm H mm	620,5 120	
Capacità di cottura pizze Pizza baking capacity Backleistung Pizzas	Nr.	8 (Ø 300 mm) 7 (Ø 350 mm) 3 (Ø 500 mm) 2 (tray 400X600 mm)	14 (Ø 300 mm) 10 (Ø 350 mm) 5 (Ø 500 mm) 4 (tray 400X600 mm)
Temperatura massima Maximum temperature Höchsttemperatur	°C	450	
Produttività oraria (pizza classica) Productivity per hour (Pizza Classic) Stunden Leistung (Pizza classica)	Nr.	80 (Ø 300 mm) 60 (Ø 350 mm) 25 (Ø 500 mm) 12 (tray 400x600 mm)	140 (Ø 300 mm) 110 (Ø 350 mm) 35 (Ø 500 mm) 24 (tray 400x600 mm)
Alimentazione elettrica Electric power supply Stromversorgung	Volt (50/60 Hz/ Гц)	AC 3 N 400V*	
Assorbimento massimo Maximum absorption Maximale Stromaufnahme	KW MAX	16,2	19,9
Consumo medio Average consumption Durchschnittlicher Verbrauch	kWh	9,7	11,9
Peso netto Net weight Nettogewicht	Kg	527	646
Peso lordo Gross weight Bruttogewicht	Kg	598	732
Dimensioni esterne con imballo External dimensions including pack Außenmaße der Verpackung	L mm	1460	1760
	P mm	1230	1350
	H mm	2021	2171

(*) Altre tensioni a richiesta - Other voltages available on request - Andere Spannungen auf Anfrage.
Cavi di alimentazione non inclusi - Power cables not included - Zuleitung nicht inklusiv.



Gestione cappa integrata
Integrated hood control
Integrierte Steuerung der Haube



MODELLO - MODEL - MODELL		AH110N	AH110V	AH140N	AH140V
Dimensioni esterne External dimensions Außenmaße	L mm	1304		1604	
	P mm	1456		1668	
	H mm	495		495	
Portata Air flow rate Abluftleistung	m³/h	-	700	-	700
Alimentazione elettrica Electric power supply Stromversorgung	Volt (50/60 Hz/ Гц)	AC 230V*			
Assorbimento massimo Maximum absorption Maximale Stromaufnahme	KW MAX	0,009	0,13	0,009	0,13
Peso netto Net weight Nettogewicht	Kg	56	61	67	72
Peso lordo Gross weight Bruttogewicht	Kg	95	100	113	118
Dimensioni esterne con imballo External dimensions including pack Außenmaße der Verpackung	L mm	1364		1664	
	P mm	1550		1770	
	H mm	660		660	

N senza aspiratore - without extractor - ohne Sauggebläse
V con aspiratore a 5 velocità - with five-speed extractor fan - mit Sauggebläse mit fünf Geschwindigkeitsstufen

Scopri il segreto della pizza napoletana perfetta con il Kit Napoli

La combinazione di una speciale pietra refrattaria e resistenze potenziate assicura una cottura uniforme ad alte temperature. Il cornicione risulterà **soffice e alveolato**, per una **pizza perfetta** in ogni dettaglio.

Discover the secrets of a perfect Pizza Neapolitana with the Napoli kit.

Combining a special refractory plate with boosted heating elements guarantees uniform baking at high temperatures. The edge will be **fluffy and airy**, for a **perfect pizza** in every detail.

Entdecken Sie das Geheimnis der perfekten neapolitanischen Pizza mit dem Kit Napoli.

Die Kombination aus einem speziellen feuerfesten Stein und verbesserten Heizelementen gewährleistet ein gleichmäßiges Backen bei hohen Temperaturen. Die Kruste wird **weich und von wabenförmiger Konsistenz**, für eine Pizza, die in jedem Detail **perfekt** ist.

Note





CUPPONE
YOUR PARTNER IN BAKING SINCE 1963



Scopri di più
Discover more
Um mehr zu erfahren

Cuppone Srl
Via Sile, 36 - 31057 Silea (TV)
Tel: +39 0422 361143
cuppone.com