

retigo®



Blast chillers/freezers

Comfort

511, 511ST

Operating manual

1. INDEX

1. INDEX.....	1
2. ANALYTICAL INDEX.....	2
3. REGULATIONS AND GENERAL INSTRUCTIONS.....	3
3.1. General information.....	3
3.2. Warranty.....	3
3.3. Replacement of Parts.....	3
3.4. Description of the Appliance	4
3.5. Features Plate	5
4. SAFETY.....	5
4.1. Safety Devices	6
5. USE AND FUNCTIONING.....	7
5.1. Description of the Functioning Cycles.....	7
5.2. Description of the Controls.....	8
5.3. Functionality	9
5.4. Recommendations for Use.....	16
6. CLEANING AND MAINTENANCE	18
6.1. Recommendations for Cleaning and Maintenance	18
6.2. Routine Maintenance	18
6.3. Extraordinary Maintenance (5T Version)	19
6.4. Extraordinary Maintenance (TABLE Version)	21
7. TROUBLESHOOTING	22
7.1. Faults Display.....	23
8. INSTALLATION	24
8.1. Packaging And Unpacking	24
8.2. Installation	25
8.3. Electric Power Supply Connection	25
8.4. Condensing unit water connection	25
8.5. Inspection	26
8.6. Parameters Programming	27
9. DISPOSAL OF THE APPLIANCE	28
10.REFRIGERANT TECHNICAL CARD	28
ATTACHMENTS.....	I

2. ANALYTICAL INDEX**B**

Blast chilling Cycle; 17

C

Cleaning the condenser; 19; 22
 Cleaning the evaporator; 19; 21
 Condensing unit water connection; 25
 Continuous cycle key; 8

D

Defrosting; 7; 14
 Defrosting Key; 8
 Description of the Appliance; 4
 Description of the Controls; 8
 Disposal of the Appliance; 28
 Door micro switch; 6

E

Electric Power Supply Connection; 25
 Evaporator Fan Micro switch; 6
 Extraordinary Maintenance (5T Version); 19
 Extraordinary Maintenance (TABLE Version); 21

F

Faults Display; 23
 Features Plate; 5

G

General information; 3

H

HACCP data printer; 13
 Heated Probe Key; 8
 High condensation temperature alarm; 6

I

Inspection; 26
 Installation; 25
 Intensive timed blast chilling; 7

N

Needle Probe Heating; 15

P

Packaging; 24
 Power Selection Key; 8
 Preservation; 7

Programmers Selection Key; 8
 Programs Memorisation; 14
 Programs Recall; 14
 Prolonged Inactivity; 16
 Protective Fuses; 6

R

Recommendations for Cleaning and Maintenance;
 18
 Recommendations for normal use; 16
 Recommendations for Use; 16
 REFRIGERANT TECHNICAL CARD; 28
 Replacement of Parts; 3
 Replacing the fuses; 20; 21
 Routine Maintenance; 18

S

SAFETY; 5
 Safety Devices; 6
 Setting Key; 8
 Setting keys; 8
 Setting the time and date; 14
 Shock freezing Cycle; 17
 START Key; 8

T

Temperature Blast Chilling; 7
 Temperature Negative Cycle; 10
 Temperature Negative Cycle Key (Shock
 Freezing); 8
 Temperature Positive Cycle Key (blast chilling); 8
 Temperature Shock Freezing; 7
 Time Blast Chilling; 7
 Time Shock Freezing; 7
 Timed Continuous Cycle; 13
 Timed Negative Cycle; 12
 Timed Negative Cycle Key; 8
 Timed Positive Cycle; 11
 Timed Positive Cycle Key; 8

U

U.V. Lamp Replacement; 20; 22
 Unpacking; 24
 UV Lamp; 15

W

Warranty; 3

3. REGULATIONS AND GENERAL INSTRUCTIONS

3.1. General information

This manual has been designed by the manufacturer to provide the necessary information to those who are authorised to interact with the appliance.

The persons receiving the information must read it carefully and apply it strictly. Reading the information contained in this document will allow the user to prevent risks to personal health and safety.

Keep this manual for the entire operating life of the equipment in a place which is well-known and easily accessible, so that it is always available when its consultation becomes necessary.

Particular symbols have been used to highlight some parts of the text that are very important or to indicate some important specifications. Their meanings are given below:

! Indicates important information regarding safety. Behave appropriately so as not to risk the health and safety of persons or cause damage.

i Indicates particularly important technical information that must not be ignored.

3.2. Warranty

The warranty of the equipment and the components we produce has duration of 1 (one) year from the date of delivery and translates into the supply, free of charge, of parts that we consider to be faulty.

These faults must, however, be independent from incorrect use of the product in compliance with the indications stated in the manual.

Fees deriving from labour, journeys and transport are excluded from the warranty.

The materials replaced under warranty are our property and must therefore be returned under the responsibility and expense of the customer.

3.3. Replacement of Parts

! Activate all envisioned safety devices before carrying out any replacement intervention.

i In particular, deactivate the electrical power supply using the differential isolating switch. Only use original spare parts to replace worn components.

i All responsibility is declined for injury to persons or damage to components deriving from the use of non-original spare parts and interventions which could modify the safety requisites, without authorisation of the manufacturer.

3.4. Description of the Appliance

5T version

The Blast chiller-Shock freezer, from now on defined as appliance, has been designed and built to cool and/or freeze foodstuffs in the professional catering ambit.

- 1) **condensation area:** it is positioned in the lower part and is characterised by the presence of the condensing unit.
- 2) **electric area:** it is positioned in the lower part of the appliance and contains the control and power supply components as well as electric wiring.
- 3) **evaporation area:** it is situated inside the refrigerated compartment in the rear and is characterised by the evaporating unit.
- 4) **storage area:** it is situated inside the refrigerated compartment and is destined for the cooling and/or freezing of foodstuffs.

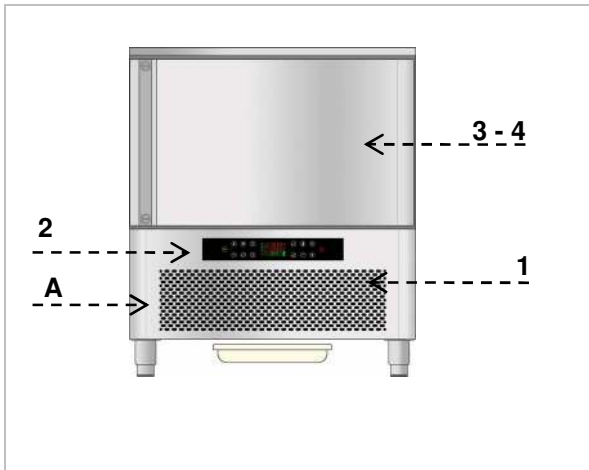

The lower part is also distinguished by a control panel (A) that allows access to the electric parts; there is a vertically-opening door in the front, which closes the refrigerated compartment hermetically.

Depending on requirements, the appliance is produced in several versions.

5 TRAY BLAST CHILLER and SHOCK FREEZER

Model suitable to contain 5 trays with blast chilling capacity of 20 kg and 12 kg in shock freezing.

TABLE version

The Blast chiller-Shock freezer, from now on defined as appliance, has been designed and built to cool and/or freeze foodstuffs in the professional catering ambit.

- 5) **condensation area:** it is positioned in the lateral part and is characterised by the presence of the condensing unit.
- 6) **electric area:** it is positioned in the lateral part of the appliance and contains the control and power supply appliance as well as electric wiring.
- 7) **evaporation area:** it is situated inside the refrigerated compartment in the rear and is characterised by the evaporating unit.
- 8) **storage area:** it is situated inside the refrigerated compartment and is destined for the cooling and/or freezing of foodstuffs.

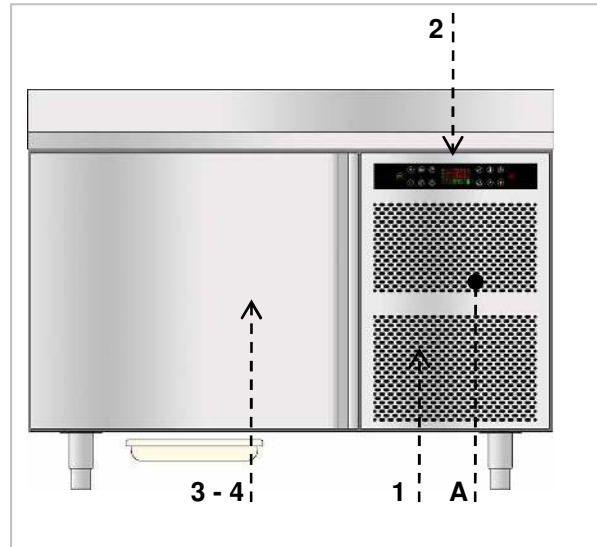

The lateral part is also distinguished by a control panel (A) that allows access to the electric parts; there is a vertically-opening door in the front, which closes the refrigerated compartment hermetically.

Depending on requirements, the appliance is produced in several versions.

GASTRONOMY BLAST CHILLER

Model suitable to contain 5 GASTRONORM 1/1 trays with blast chilling capacity of 20 kg and 12 kg in shock freezing.

CONFECTIONERY BLAST CHILLER



Model suitable to contain 5 CONFECTIONERY 400x600 trays with blast chilling capacity of 20 kg and 12 kg in shock freezing.

GB

3.5. Features Plate

The identification plate shown is applied directly onto the appliance. It states the references and all indications indispensable for working in safety.

- 1) Appliance code
- 2) Description of the appliance
- 3) Serial number
- 4) Power supply voltage and frequency
- 5) Electrical absorption
- 6) Climatic class
- 7) Type and Amount of refrigerant gas
- 8) WEEE symbol

CODICE CODE / KODE		1
MODELLO MODEL/MODELL		2
MATRICOLA SERIAL No/SERIEN NR.		3
TENSIONE TENSION/SPANNUNG		4
INPUT LEISTUNGS-AUFNABME POTENZA		5
CLIMATIC CLASS KLIMAKLASSE CLASSE CLIMATICA		6
REFRIGERANT KUEHLMITTEL REFRIGERANTE		7
  		8

4. SAFETY

i It is recommended to carefully read the instructions and warnings contained in this manual before using the appliance. The information contained in the manual is fundamental for the safety of use and for machine maintenance.

! Keep this manual carefully so that it can be consulted when necessary.

i The electric plant has been designed in compliance with the IEC EN 60335-2-24 Standard.

; Specific adhesives highlight the presence of mains voltage in the proximity of areas (however protected) with risks of an electrical nature.

! Before the connection, ensure the presence of an omnipolar switch with minimum contacts opening equal to 3 mm in the mains power supply upstream from the appliance (requested for appliances supplied without plug to connect to the fixed plant).

In the design and construction phase, the manufacturer has paid particular attention to the aspects that can cause risks to safety and health of persons that interact with the appliance.

Carefully read the instructions stated in the manual supplied and those applied directly to the machine, and particularly respect those regarding safety.

Do not tamper or eliminate the installed safety devices. Failure to comply with this requisite can lead to serious risks for personal health and safety.

It is recommended to simulate some test manoeuvres in order to identify the controls, in particular those relative to switch-on and switch-off and their main functions.

The appliance is only destined for the use for which it has been designed; any other use must be considered improper.

i The manufacturer declines all liability for any damage to objects or injury to persons owing to improper or incorrect use.

i All maintenance interventions that require precise technical skill or particular ability must be performed exclusively by qualified staff.

! When using the appliance, never obstruct the air inlet when the appliance is on, so as not to compromise its performance and safety.



! Never stretch the power cable.

In order to guarantee hygiene and protect the foodstuffs from contamination, the elements that come into direct or indirect contact with the foodstuffs must be cleaned very well along with the surrounding areas. These operations must only be performed using detergents that can be used with foodstuffs, avoiding inflammable products or those that contain substances that are harmful to personal health.

In the case of prolonged inactivity, as well as disconnecting all the supply lines, it is necessary to accurately clean all internal and external parts of the appliance.

4.1. Safety Devices

During the running of appliance, some control devices may activate and govern the correct running of the machine. In other cases, they may deactivate parts or the whole machine, to put the appliance in safe conditions. Main controls are described below.

Door micro switch



If the door is opened, the magnetic switch placed on the control board opens and, during blast-chilling or shock-freezing, evaporator fans go off and a warning message appears on the display at the same time. This condition may also be determined when the door is not perfectly aligned to or near the control board: in this case with machine in **STOP** phase, cycle start-up is prevented, apart from start-up of the defrosting cycle.

If a U.V. sterilisation cycle is active, the functioning of the U.V. lamp is interrupted. The cycle continues when the door is closed.

Protective Fuses

Some protection fuses in the general power supply line are activated in case of overload.

High condensation temperature alarm



In the event of room conditions or functional failures, which cause the condenser to exceed the maximum temperature value, an alarm is triggered and stops the machine running. The machine can be run when an acceptable temperature value is reset.

Evaporator Fan Micro switch



If the deflector is opened to inspect the evaporator or fans, this micro switch positioned on the evaporator deflector, deactivates machine functioning. Closure of the deflector with the successive disappearance of the alarm on the display, restores normal machine functioning.

GB

5. USE AND FUNCTIONING

5.1. Description of the Functioning Cycles

The following are brief descriptions and types of operating cycles.



Temperature Blast Chilling

This cycle allows a reduction in temperature in the product core from **+90°C** to **+3°C** as quickly as possible and within a MAX time of **90 minutes**. The cycle ends when the value **+3°C**, read by the needle probe, is reached.



Time Blast Chilling

This cycle allows a reduction in temperature in the product core from **+90°C** to **+3°C** during the set time: we remind you that it is advisable to run some previous testing temperature cycles so to determine the necessary time for a correct product blast chilling process. Do not forget that acquired times and eventually memorised have to be considered valid for exclusive use of the same type of product and in the same quantities per cycle.

There are 5 levels of power available: to every level corresponds an air temperature and specific ventilation.



Temperature Shock Freezing

This cycle allows a reduction in temperature in the product core from **+90°C** to **-18°C** as quickly as possible and within a MAX time of **270 minutes**. The cycle ends when the value **-18°C**, read by the needle probe, is reached.



Time Shock Freezing

This cycle allows a reduction in temperature in the product core from **+90°C** to **-18°C** during the set time: we remind you that it is advisable to run some previous automatic test cycles so to determine the necessary time for a correct product blast chilling process. Do not forget that acquired times and eventually memorised have to be considered valid for exclusive use of the same

type of product and in the same quantities per cycle.

Preservation

At the end of each cycle as described above, either temperature or time cycle, the preservation cycle will be started automatically, with no time limit. The freezer temperature will refer to last cycle, just concluded:

- **+3°C** for blast chilling
- **-25°C** for shock-freezing

Warning: use of this cycle is recommended only for short periods prior to storage of the product in a storage unit or in case of emergency, so as to avoid such a limited use of a machine with such high potential.



Continuous Cycle

This key enables selecting a continuously timed cycle. Just set the cell temperature and start the machine. It is possible to amend the fans speed depending on the specific requirements. The appliance maintains the set temperature, defrosting is automatically managed. The cell temperature can be amended during normal functioning. It is possible to use this cycle when large amounts of food must be blast chilled and the blast chilling time specific for each product is known.



Defrosting

The frost forming on the evaporator following the deposit of humidity from the product can jeopardise the correct functioning of the appliance. A defrosting cycle must be carried out to restore full functionality.

Defrosting is performed by forced ventilation using the evaporator fan. The cycle can be performed with the door open or closed and can also be interrupted at any time.

5.2. Description of the Controls

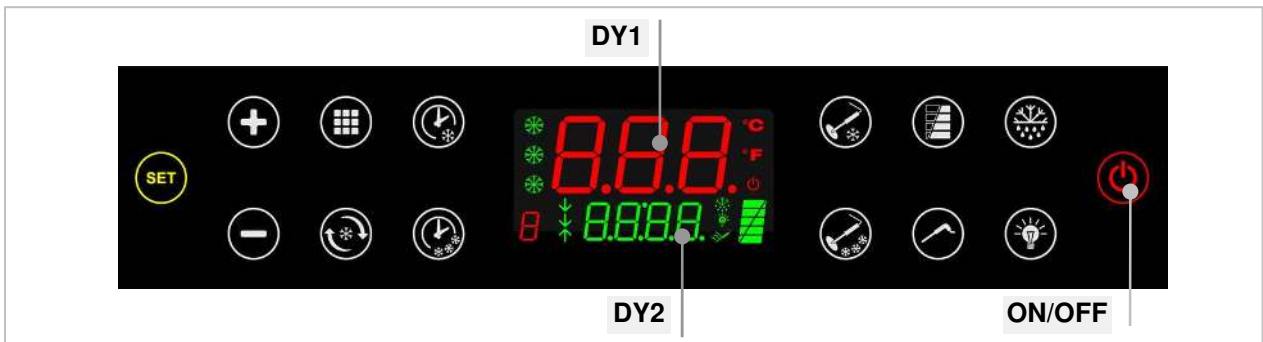

Below is a brief description of the functions carried out by the keys on the control panel.



Temperature Positive Cycle Key (blast chilling)

This key enables selecting the temperature blast chilling cycle (+90°Cà+3°C).



Temperature Negative Cycle Key (Shock Freezing)

This key enables selecting the temperature shock freezing cycle (+90°Cà-18°C)



Timed Positive Cycle Key

This key enables selecting the timed blast chilling cycle.



Timed Negative Cycle Key

This key enables selecting the timed shock freezing cycle.



Heated Probe Key

In appliances in which the needle probe can be heated, once this key is pressed with the machine stopped, makes it possible to heat the needle probe so that it is easier to pull it out of the frozen product.

If during a chilling / freezing cycle the "needle



and Setting keys

If timed chilling or freezing mode has been selected, these keys make it possible to set the number of minutes the cycle will last. This setting is made prior to pressing the start key . In programming they enable setting the parameters.

In programs selection they enable choosing the wanted program.



START Key

Pressing the key starts a work cycle. Pressed for at least 3 seconds interrupts the cycle in progress.

By pressing this button for at least 5 seconds the machine passes to the stand-by mode. Repeat the procedure to reactivate the board.



Defrosting Key

When the machine is off a manual defrosting cycle can be started.

If the key is pressed again, the defrosting in progress can be stopped.



Programmers Selection Key

With machine still, enables recalling or memorizing a work program.



Setting Key

With the machine at standstill, it enables setting the current date and time.

Pressed for at least 5 seconds, it enables setting the appliance parameters.



Power Selection Key

This key enables selecting the power of the work cycle.



Continuous cycle key

This key enables selecting a continuously timed cycle. It is possible to set the work temperature of the cell.

5.3. Functionality

Temperature Positive Cycle (Blast Chilling +90°C → +3°C)



Select the positive cycle: . The LED relating to positive cycle (1) switch-on. The displays respectively show the temperature of the needle and the cycle time (90 minutes).

Select the wanted power level : the LED relating to the pre-chosen power (2) switch-on. There are 5 levels of power available.





After level 5, it is also possible to choose the

automatic power level  (automatic cycle).

The automatic power level  is proposed by default.

Start the cycle by pressing key . During the first minutes of operation, the control unit checks the exact positioning of the needle probe.

If verification has negative result, LED (3)  intermittently switches on and the buzzer is activated: it is possible to eliminate the alarm by

pressing key : the cycle re-starts normally. Whereas, if no choice is made, after a few seconds the controller starts a timed positive blast chilling cycle.

LED (5)  relating to the blast chilling phase switch-on. The displays respectively show the temperature read by the product probe and the missing time.

If the product has not reached 3°C after 90 minutes the cycle is not concluded: the buzzer is triggered intermittently, the displays respectively show the temperature of the product and "out".

The blast chilling cycle is concluded successfully as soon as the temperature measured by the product probe reaches 3°C: the buzzer is triggered intermittently, the displays respectively show the temperature of the product and "End". A preservation cycle is automatically started. The

preservation phase LED (5)  switch-on. It is possible to display the temperature read by

the cell probe by pressing key : when the cell probe is displayed, the bottom left icon (6) displays the symbol "-".

Pressing key  during preservation shows the memorised cycle time in the lower display for five seconds.

Press  to conclude the preservation cycle.

GB

Temperature Negative Cycle (Shock Freezing +90°C → -18°C)



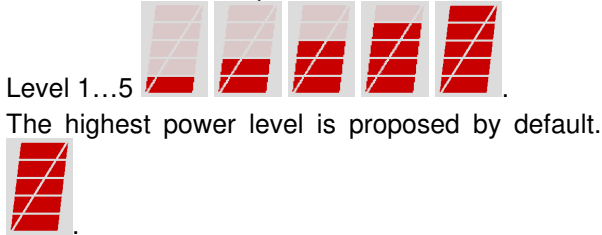

Select the negative cycle: . The LED relating to negative cycle (1) switch-on. The displays respectively show the temperature of the needle and the cycle time (270 minutes).

Select the wanted power level : the LED relating to the pre-chosen power (2) switch-on. There are 5 levels of power available.



Start the cycle by pressing key . During the first minutes of operation, the control unit checks the exact positioning of the needle probe.

If verification has negative result, LED (3)  intermittently switches on and the buzzer is activated: it is possible to eliminate the alarm by

pressing key : the cycle re-starts normally. Whereas, if no choice is made, after a few seconds the controller starts a timed negative blast chilling cycle.

LED (5)  relating to the shock freezing phase switch-on. The displays respectively show the temperature read by the product probe and the missing time.

If the product has not reached -18°C after 270 minutes the cycle is not concluded: the buzzer is triggered intermittently, the displays respectively show the temperature of the product and "out". The shock freezing cycle is concluded successfully as soon as the temperature measured by the product probe reaches -18°C: the buzzer is triggered intermittently, the displays respectively show the temperature of the product and "End".

A preservation cycle is automatically started. The preservation phase LED (5)  switch-on. It is possible to display the temperature read by

the cell probe by pressing key : when the cell probe is displayed, the bottom left icon (6) displays the symbol "-".

Pressing key  during preservation shows the memorised cycle time in the lower display for five seconds.

Press  to conclude the preservation cycle.

GB

Timed Positive Cycle



Select the positive cycle: . The LED relating to positive cycle (1) switch-on. The displays respectively show the temperature read by the cell probe and the cycle time (90 minutes).

Select the wanted power level : the LED (2) relating to the pre-chosen power switch-on. There are 5 levels of power available.



The intermediate power level is proposed by default.

Select the wanted blast chilling time by pressing keys and (keep pressed to speed up operation).

Start the cycle by pressing key . In timed cycle the needle probe correct insertion verification test is not performed.

LED (3) relating to the blast chilling phase switch-on. The displays respectively show the temperature read by the cell probe and the residue time. It is possible to display the temperature read by

the product probe by pressing key : when the product probe is displayed, the bottom left icon (6) displays the symbol "1". After 5 seconds, the display again shows the temperature read by the cell probe.

Once the set time has past, the appliance automatically passes to positive preservation. The

preservation phase LED (3) switch-on. The displays respectively show the temperature read by the cell probe and "End".

It is possible to display the temperature read by the product probe by pressing key : Press to conclude the preservation cycle.

GB

Timed Negative Cycle



Select the negative cycle: . The LED relating to negative cycle (1) switch-on. The displays respectively show the temperature read by the cell probe and the cycle time (270 minutes).

Select the wanted power level : the LED relating to the pre-chosen power (2) switch-on.

There are 5 levels of power available.



The highest power level is proposed by default.

Select the required shock freezing time using keys and . (keep pressed to speed up operation).

Start the cycle by pressing key . In timed cycle the needle probe correct insertion verification test is not performed.

The shock freezing phase LED (3) switch-on. The displays respectively show the temperature read by the cell probe and the residue time.

It is possible to display the temperature read by the product probe by pressing key : when the product probe is displayed, the bottom left icon (6) displays the symbol "1". After 5 seconds, the display again shows the temperature read by the cell probe.

Once the set time has past, the appliance automatically passes to negative preservation.



The preservation phase LED (3) switch-on. The displays respectively show the temperature read by the cell probe and "End".



It is possible to display the temperature read by the product probe by pressing key : Press to conclude the preservation cycle.

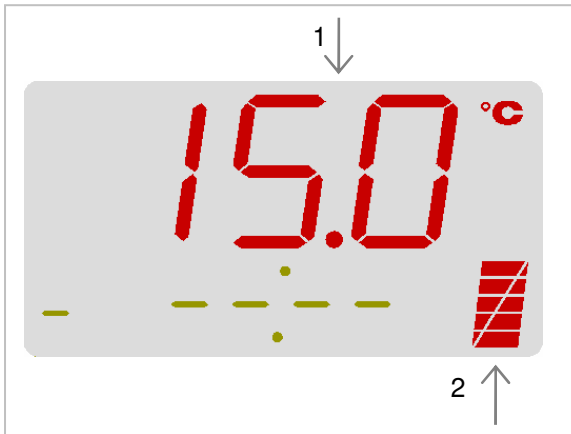

GB

Timed Continuous Cycle



Select the continuous cycle: .
 The upper display shows the set cell temperature. The time shown in the lower display is not settable "--:--". Using keys  and  it is possible to amend the work temperature of the cell. Using

key  it is possible to set the ventilation power (2). Start the cycle by pressing key . The displays respectively show the temperature read by the cell probe and the elapsed time.

Using keys  and  during functioning, makes it possible to amend the work temperature of the cell.

It is possible to display the temperature read by the product probe by pressing key . Defrosting management is automatic.

Press key  for at least three seconds to conclude the cycle.

GB

HACCP data printer (Optional)

If the printer is enabled, the following events are printed:

- **print heading** : date, time and selected cycle;
- **cycle start**: cell probe and product probe temperature;
- **alarms** : type of alarm, time, product probe and cell probe temperature;
- **cycle end**: time, compartment and needle temperature;
- **start preservation**: time, product probe and cell probe temperature;
- **Defrost**: time, product probe and cell probe temperature;
- **alarms** : HACCP type of alarm, time, product probe and cell probe temperature;
- **preservation record**: time, product probe and cell probe every 30 minutes.

Alarms which can be printed out are:
DOOR →Door opening
HT →Cell high temperature alarm.
LT →Cell low temperature alarm.
 A printing example follows.

```

*****
Cycle:
- Positive
- Intensive
- Shaft
19/01/11 11:08
*****
KEY

TC=CELL TEMPER
TP=PRODUCT TEMPER
HT=HIGH T. ALARM
LT=LOW T ALARM
*****
COOLING
*****
00:00 START
TC      30°C
TP      70°C
04:20 END
TC      -35°C
TP      -18°C
*****
STORING
*****
16:35 HT
TC      5°C
TP      -20°C
13:35 LT
TC      -40°C
TP      -22°C
17:20 STOP
TC      -25°C
TP      -21°C
    
```

Programs Memorisation

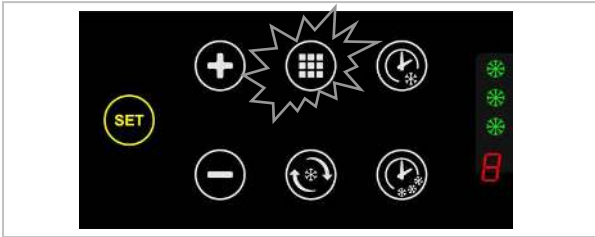

To memorise a work cycle, set it as if it were a timed program in machine standstill mode. Instead of starting the cycle press for at least five

seconds the programming key : a beep of the buzzer confirms the input into programs memorisation.

The upper display will show the label **P** followed by the selected program number (for example **P01**).

The already occupied programs will show “**buSY**” on the lower display.

The free programs will show “**FrEE**” on the lower display.

Using keys  and , select the number of program to memorise, press the programming

key  again to confirm memorisation.

If a program is selected with already existing data, this will be overwritten.

If a key is not pressed for ten seconds, the programs memorisation procedure is cancelled.

Programs Recall



With the machine stopped, press and release the

programming key .

For each selected program, the following information appears on the display:

1. label **P** followed by the selected program number (for example **P01**),
2. the type of cycle: positive or negative
3. the memorised time for that particular cycle
4. the power level associated to that program

Select the required program using keys  and



If you select a program that has not been memorised, the time display will show “---”.

Once the required program has been selected,

press .

4.4.3. Setting the time and date

Make sure the machine is at stand-still.

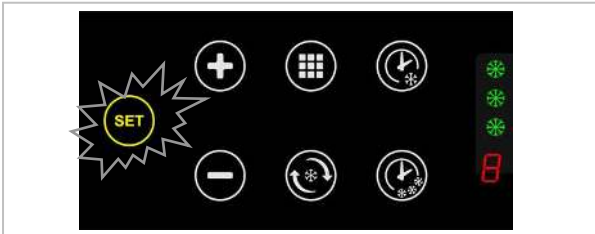

To access time setting, press .

The upper display will show labels **Hr** (hours), **Mn** (minutes), **dA** (day), **Mo** (month) and **Yr** (year), whereas the lower display will, from time to time, show the settings relating to the upper display label.

Press  to scroll the

labels, whereas by pressing keys  and



the relative values can be updated. Exit



timer setting by pressing  for at least 3 seconds or due to timeout of 10 seconds.

The new data set for the timer is immediately active

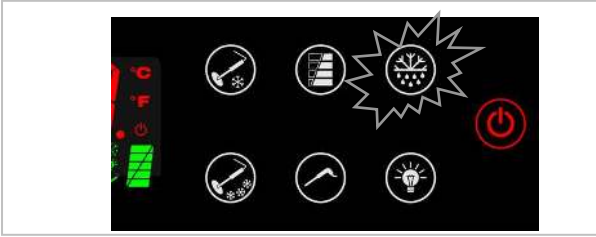
Defrosting



Make sure the machine is at stand-still.

To select the defrosting cycle press , pressing key  confirms the choice and starts the cycle. The lower display shows the elapsed time.



Defrosting is performed by forced ventilation using the evaporator fan. Once the defrosting cycle has ended, the buzzer is intermittently activated.

The cycle is automatically interrupted at the end of the envisioned time. It is possible to manually interrupt the cycle by

pressing key  for at least three seconds.

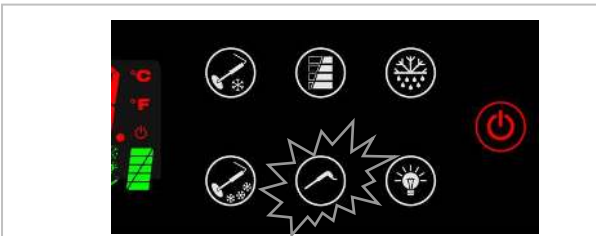
Needle Probe Heating (Optional)



To select the needle probe heating cycle press, press key , pressing key  confirms the choice and starts the cycle.

At the end of a work cycle, the product probe heating cycle facilitates removal of the probe from the frozen product.

This function is not active if:

- the needle probe provided is not a type which can be heated
- the temperature of the needle probe is greater than 0°C



The cycle is automatically interrupted at the end of the envisioned time.

It is possible to manually interrupt the cycle by

pressing key  for at least three seconds.

UV lamp (Optional)



To select the disinfection cycle press , pressing key  confirms the choice and starts the cycle.

This cycle can be started only with the door closed and it will immediately be interrupted if the door is opened during sterilization.

The upper display shows the temperature read by the cell probe, the lower display shows the

residue time, the relative icon switches on: .

The cycle is automatically interrupted at the end of the envisioned time.

It is possible to manually interrupt the cycle by

pressing key  for at least three seconds.

For correct machine efficiency and hygiene, it is advisable to disinfect the cell at the end of every work shift.

5.4. Recommendations for Use

Prolonged Inactivity

If the appliance remains inactive for a long period, proceed as follows:

1. Use the automatic isolating switch to deactivate connection to the main electrical line.
2. Clean the appliance and surrounding areas thoroughly;
3. Spread a thin layer of cooking oil onto the stainless steel surfaces;
4. Carry out all maintenance operations;
5. Leave the doors ajar to prevent the formation of mould and/or unpleasant odours.

Recommendations for normal use

In order to ensure correct use of the appliance, it is good practice to apply the following recommendations:

! Do not obstruct the zone in front of the condensing unit in order to favour heat disposal from the condenser to a maximum. Always keep the front of the condenser clean.

á Do not insert foodstuffs that are well above the temperature of 90°C. As well as initially overloading the machine it can make protections intervene that prolong temperature descent times. If possible, a brief external period is useful to lower the temperature to acceptable values. Check the planarity of the appliance rest surface.

i Do not stack the materials to be preserved in contact with the internal walls, so blocking the circulation of air, which guarantees uniformity of the internal temperature of the refrigerated compartment.

i There must be a sufficient space between the basins and trays used in order to guarantee a sufficient flow of cold air on the entire product. Therefore avoid the following positions of trays and/or basins stated below.

i Never obstruct the inlet of the evaporator fans.

i Products that are more difficult to chill because of their composition and size should be placed in the centre.

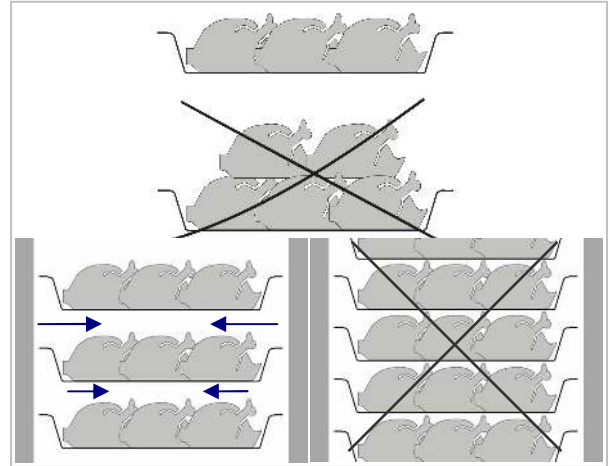

Limit the number of times and the duration of time the doors are opened.

! Blast chilling data refer to standard products (low fat content) with a thickness below 50 mm; therefore avoid overlaying products or the insertion of pieces with a much higher thickness. This would, in fact, lead to an extension of blast chilling times. Always distribute the product well on the trays or basins or in the case of thick pieces decrease the amount to blast chill.

i After blast chilling/shock freezing the product, it can be stored in a preservation cabinet after having been duly protected. A tag should be applied describing the contents of the product, blast chilling/shock freezing date and expiry date. *When the product has been blast chilled it must be preserved at a constant temperature of +2°C , while if it has been shock frozen it must be preserved at a constant temperature of -20°C .*







i The chiller should be used for storage for short periods only.

! **To prevent bacterial contamination or contamination of any other biological nature, the needle probe must be disinfected after use.**

! To extract the product that has undergone blast chilling or shock freezing, always wear gloves to protect the hands, as "burns" may occur from the cold.

Blast chilling Cycle

The blast chilling cycle envisions two phases with specific ventilation percentages and temperatures. Listed below are the functioning percentages and temperatures of each individual phase:

Power Level		1	2	3	4	5	AUTO
	Display						
Phase1	Air Temperature [°C]	0°C	0°C	0°C	-15°C	-20°C	AUTO
	% Ventilation	50%	75%	100%	100%	100%	AUTO
Phase2	Air Temperature [°C]	0°C	0°C	0°C	0°C	0°C	0°C
	% Ventilation	50%	75%	100%	100%	100%	AUTO

When the product reaches the pre-set temperature, the appliance automatically passes to phase two.

The 1,2 and 3 power level has been conceived for delicate products, in which the appearing of ice crystals on the product surface is common.





The 4 and 5 power level maintains during initial phase, a value of the air temperature much below zero, in order to accelerate the product

temperature drop. This type of chilling must be preferred for packed products or products whose physical/organoleptic characteristics would not be damaged by superficial ice.

The default mode is "AUTO": in this mode, the air temperature and ventilation are automatically calculated depending on the type and the amount of product inserted in the appliance.

Shock freezing Cycle

The shock freezing cycle envisions two phases with specific ventilation percentages and temperatures. Listed below are the functioning percentages and temperatures of each individual phase:

Power Level		1	2	3	4	5
	Display					
Phase1	Air Temperature [°C]	-3°C	-9°C	-15°C	-20°C	-35°C
	% Ventilation	50%	75%	100%	100%	100%
Phase2	Air Temperature [°C]	-35°C	-35°C	-35°C	-35°C	-35°C
	% Ventilation	50%	75%	100%	100%	100%

When the product reaches the pre-set temperature, the appliance automatically passes to phase two.

The 1, 2 and 3 power level has been conceived for delicate products, to avoid ice forming externally with still high core temperature. With certain products, this type of shock freezing enables a more even product freezing.

The 4 and 5 power level maintains the temperature value in the cell below -18°C, (which is the end shock freezing temperature).

The default mode is number 5.

IFor shock freezing to be successful and fast, food should be in small pieces, especially if it has a high fat content. The largest pieces should be placed in central trays. If it takes longer than standard time to shock freeze and the sizes cannot be reduced, decrease the quantity and precool the chiller compartment by starting an empty shock freezing cycle before shock freezing the product.

6. CLEANING AND MAINTENANCE

6.1. Recommendations for Cleaning and Maintenance

! Activate all envisioned safety devices before carrying out any maintenance interventions. In

particular, deactivate the electrical power supply using the automatic isolating switch.

6.2. Routine Maintenance

Routine maintenance consists of daily cleaning of all the parts which can come into contact with foodstuffs and the periodic maintenance of the burners, nozzles and draining pipes.

Correct maintenance allows the user to maximise performance levels and operating life and constantly maintain safety requirements.

Do not spray the appliance with direct jets of water or using high pressure appliances.

Do not use iron wool, brushes or scrapers to clean the stainless steel as ferrous particles could be deposited which, on oxidising, could lead to rust.

To remove hardened residues, use wooden or plastic spatulas or abrasive rubber pads.

During long periods of inactivity, spread a protective layer on all stainless steel surfaces by wiping them with a cloth soaked in Vaseline oil and airing the rooms periodically.

! Do not use products which contain substances which are harmful and dangerous for personal health (solvents, petrol etc.).

At the end of the day it is advisable to clean:

- the cooling compartment
- the appliance.

6.3. Extraordinary Maintenance (5T Version)

Have the following operations carried out **periodically** by specialised staff:

- Check the perfect sealing of the door gaskets and replace them if necessary.
- Check that the electric connections have not loosened.
- Check the efficiency of the heating element resistance
- Check functioning of the board and probes.
- Check the efficiency of the electrical system.
- Clean the evaporator.
- Clean the condenser.

Cleaning the evaporator

Clean the evaporator **periodically**.

! As the fins of the evaporator are very sharp, always wear protective gloves for the next phases. Only a brush must be used for cleaning: do not use jets of liquid or sharp instruments. To access the evaporator proceed as follows:

1. Open the door (**A**) of the appliance.
2. Loosen the two screws (**B**) on the right of the deflector.
3. Remove the runners (**C**):
4. Turn the deflector (**D**) to the left

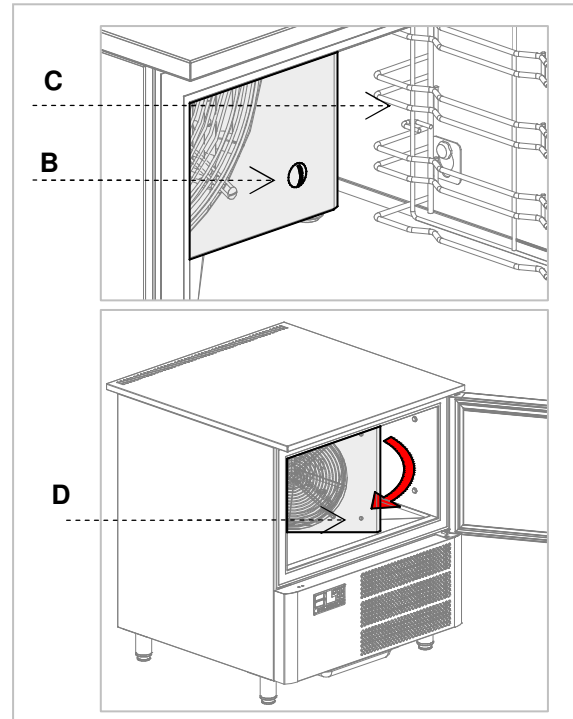
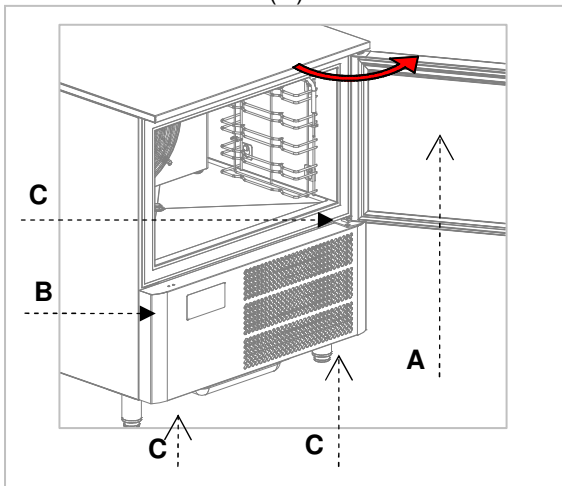

Cleaning the condenser

Clean the condenser **periodically**.

! As the fins of the condenser are very sharp, always wear protective gloves for the next phases. Use protective masks and glasses in the presence of dust.

i Whenever the condenser has a deposit of dust in correspondence with the fins, this can be removed using a suction device or with a brush applied, using a vertical movement along the direction of the fins.

! No other instruments must be used, which may deform the fins and therefore the efficiency of the appliance.

To clean, proceed as follows:

1. Open the door (**A**) of the appliance.
2. Remove the lower panel (**B**) from the technical compartment: to do this, remove the screw fasteners (**C**).
3. It is now possible to clean the finned part of the condenser (**D**) using suitable tools and protection devices.
4. After cleaning, close the control panel and fix it with the screws removed beforehand.

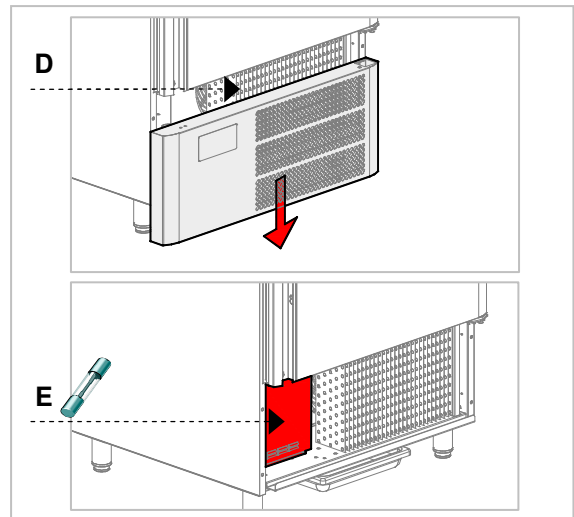
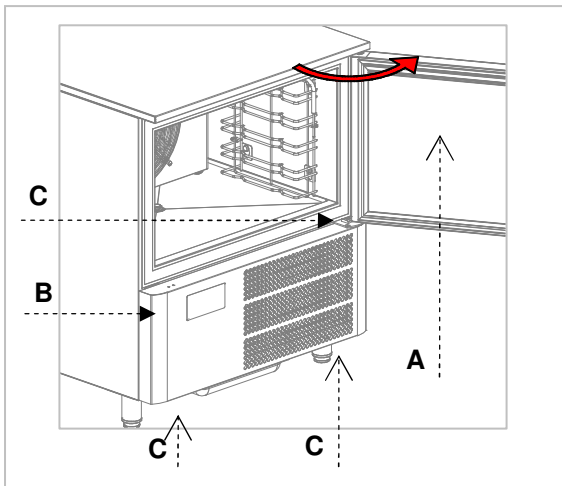

Replacing the fuses

i The fuses are in the lower part of the technical compartment (E). To access these, open the

control panel using the same method listed for the access and cleaning of the condenser.

U.V. Lamp Replacement

After having removed the flush sliders, remove the screws that fix the evaporator deflector onto the right side (A).

Access the UV lamp. This lamp can be removed by sliding it upwards (B). Carry out all the operations in reverse order after having removed the U lamp.

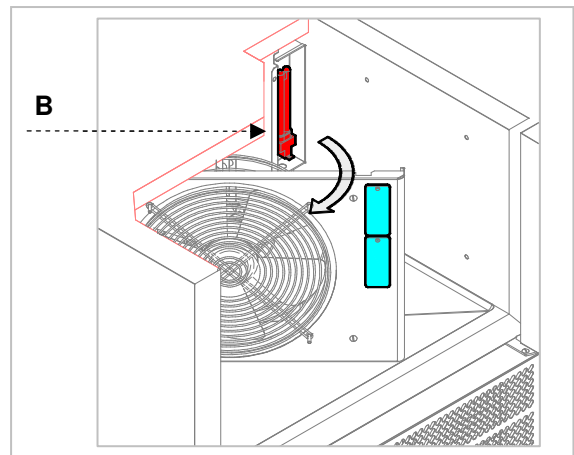
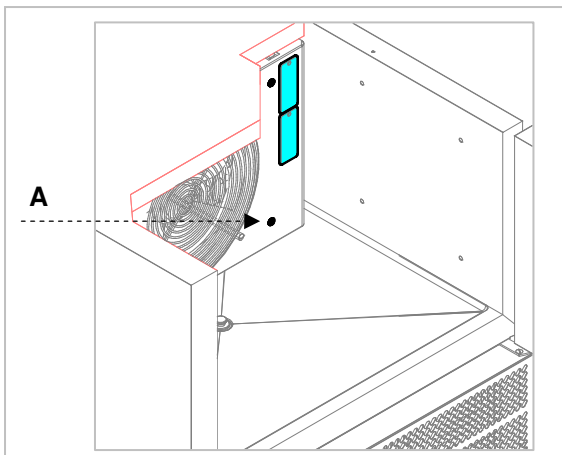

Once you have removed the screws, the evaporator deflector can be opened by turning it.

6.4. Extraordinary Maintenance (TABLE Version)

Have the following operations carried out **periodically** by specialised staff:

- Check the perfect sealing of the door gaskets and replace them if necessary.
- Check that the electric connections have not loosened.
- Check the efficiency of the heating element resistance
- Check functioning of the board and probes.
- Check the efficiency of the electrical system.
- Clean the evaporator.
- Clean the condenser.

Cleaning the evaporator

Clean the evaporator **periodically**.

! As the fins of the evaporator are very sharp, always wear protective gloves for the next phases. Only a brush must be used for cleaning: do not use jets of liquid or sharp instruments. To access the evaporator proceed as follows:

5. Open the door (A) of the appliance.
6. Loosen the two screws (B) on the right of the deflector.
7. Remove the runners (C):
8. Turn the deflector (D) to the left

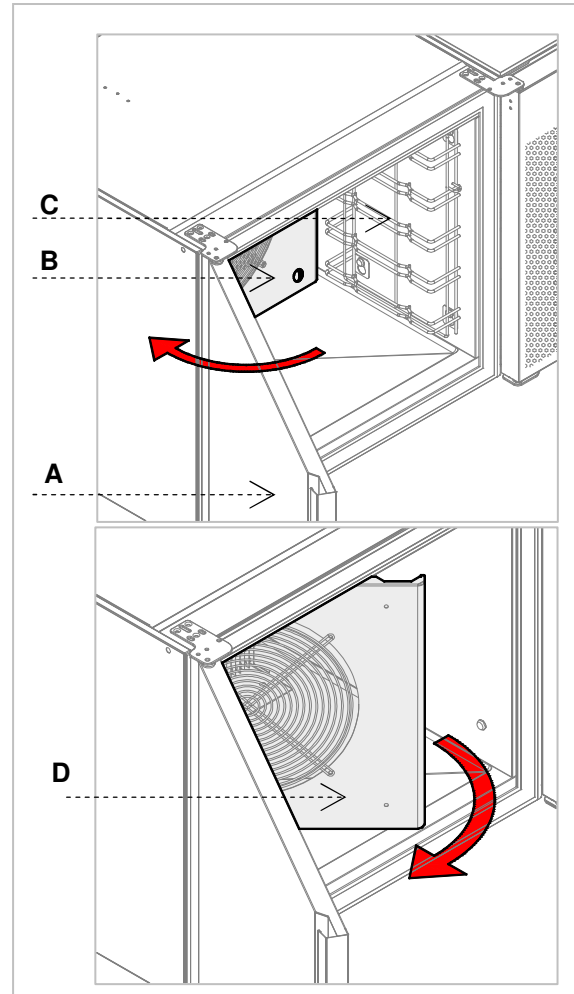

Replacing the fuses

i The fuses are in the lower part of the technical compartment (E). To access these, open the control panel using the same method listed for the access and cleaning of the condenser.

Cleaning the condenser

Clean the condenser **periodically**.

! As the fins of the condenser are very sharp, always wear protective gloves for the next phases. Use protective masks and glasses in the presence of dust.

i Whenever the condenser has a deposit of dust in correspondence with the fins, this can be removed using a suction device or with a brush applied, using a vertical movement along the direction of the fins.

! No other instruments must be used, which may deform the fins and therefore the efficiency of the appliance.

To clean, proceed as follows:

5. Open the door (A) of the appliance.
6. Turn the lateral panel (B) from the technical compartment: to do this, remove the screw fasteners (C).
7. It is now possible to clean the finned part of the condenser (D) using suitable tools and protection devices.
8. After cleaning, close the control panel and fix it with the screws removed beforehand.

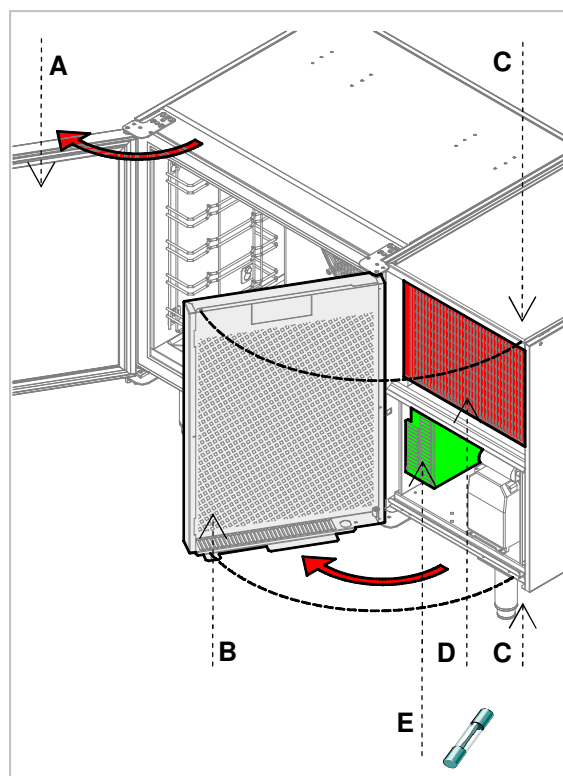

U.V. Lamp Replacement

After having removed the flush sliders, remove the screws that fix the evaporator deflector onto the right side (A).

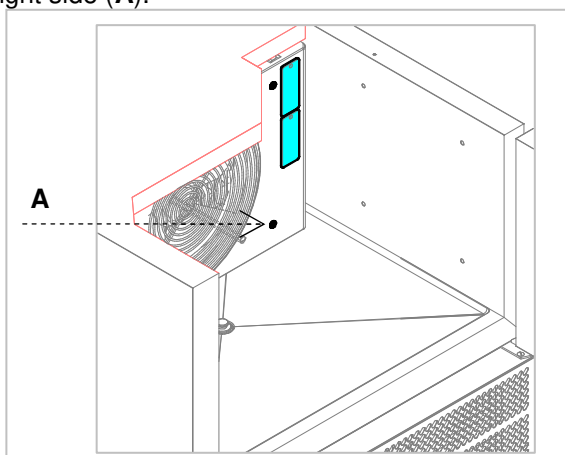

Once you have removed the screws, the evaporator deflector can be opened by turning it. Access the UV lamp. This lamp can be removed

by sliding it upwards (B). Carry out all the operations in reverse order after having removed the U lamp.

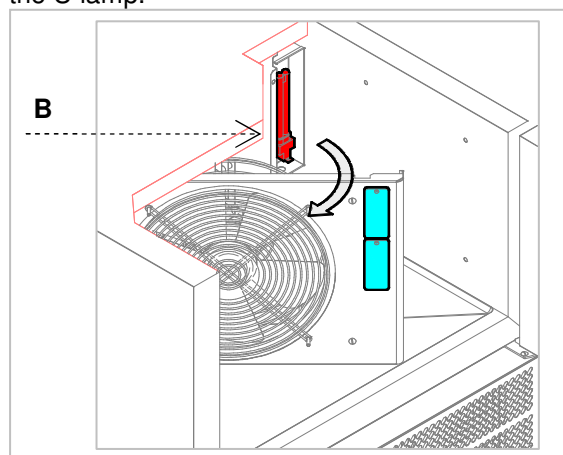

7. TROUBLESHOOTING

The information shown below aims to help with the identification and correction of any anomalies and malfunctions which could occur during use. Some of these problems can be resolved by the

user. For the others, precise skill is required and they must therefore only be carried out by qualified staff.

Problem	Causes	Solutions
The refrigerator unit does not start	No voltage	Check the power supply cable.
		Check fuses.
	Check the correct connection of the appliance.	
	Other causes	@ If the problem persists, contact the after-sales centre.
The refrigerator unit functions continuously, cooling insufficiently	Room too hot	Air the environment
	Dirty condenser	clean the condenser
	Insufficient door sealing	check the gaskets
	Insufficient quantity of refrigerant gas	@ Contact the after-sales centre.
	Condenser fan at a standstill	@ Contact the after-sales centre.
The refrigerator unit does not stop	Probe faulty	@ Contact the after-sales centre.
	Circuit board fault	@ Contact the after-sales centre.
Presence of ice inside the evaporator		Carry out a defrosting cycle possibly with the door open.
		@ If the problem persists, contact the after-sales centre.
Appliance noise	Persistent vibrations	check there is no contact between the appliance and other objects inside or outside

7.1. Faults Display

Problem	Causes	Solutions
"E0" flashes on the display and the buzzer emits an intermittent noise (compartment probe error)	<ul style="list-style-type: none"> ➤ The type of probe is incorrect. ➤ The probe is faulty. ➤ The probe – circuit board connection is incorrect. 	@ Contact the after-sales centre. <ul style="list-style-type: none"> ➤ Check that the compartment probe is the PTC type.
"E2" flashes on the display and the buzzer emits an intermittent noise (condenser probe error)	<ul style="list-style-type: none"> ➤ The temperature detected by the probe is out of the limits accepted by the compartment probe in use 	<ul style="list-style-type: none"> ➤ Check the integrity of the compartment probe. ➤ Check correctness of the instrument - probe connection. ➤ Check that the temperature in proximity of the compartment

<p>"E3" flashes on the display and the buzzer emits an intermittent noise (needle probe error)</p>		<p>probe is not out of the accepted limits</p>
<p>"dFL" flashes on the display and the buzzer emits an intermittent noise</p>	<p>The evaporator fan deflector has been opened.</p>	<p>@ Contact the after-sales centre. Close the evaporator fan deflector.</p>
<p>"Ht" flashes on the display and the buzzer emits an intermittent sound (high condensation temperature alarm)</p>	<p>The condenser temperature has exceeded the set limit.</p>	<p>@ Contact the after-sales centre.</p> <ul style="list-style-type: none"> ➤ Air the environment. ➤ Clean the condenser ➤ Check that the fans function correctly.

GB

8. INSTALLATION

8.1. Packaging And Unpacking

Handle and install the appliance respecting the information provided by the manufacturer, shown directly on the packaging, on the appliance and in this manual.

The lifting and transportation system of the packaged product envisions the use of a fork-lift truck or a pallet stacker. When using these, particular attention must be paid to balancing the weight in order to prevent the risk of overturning (avoid excessive tilting!).

! **ATTENTION:** When inserting the lifting device, pay attention to the power supply cable and the position of the feet.

The packaging is made of cardboard and the pallet of wood. A series of symbols is printed on the cardboard packaging which highlights, in accordance with international standards, the provisions to which the appliances are subjected during loading, unloading, transport and storage.



On delivery, check that the packaging is intact and has not undergone any damage during transportation.

The transportation company must be notified of any damage immediately.

The appliance must be unpacked as soon as possible to check that it is intact and undamaged. Do not cut the cardboard with sharp tools so as not to damage to the steel panels underneath.

Pull the cardboard packaging upwards.

After having unpacked the appliance, check that the features correspond to those requested in the order;

Contact the dealer immediately if there are any anomalies.

! Packaging elements (nylon bags, polystyrene foam, staples ...) must not be left within reach of children.

Remove the protective PVC film from the internal and external walls, avoiding the use of metal tools.

8.2. Installation

All the installation phases must be considered, from the moment of creation of the general plan.

The installation area must be equipped with all power supply and production residue drainage connections and must be suitably lit and respect current laws regarding hygiene and sanitary requirements.

i The performance of the appliance is guaranteed with a room temperature of 32°C. A higher temperature can compromise its performance and, in more serious cases, cause the appliance's protections to start up.

Therefore, consider the most critical room conditions that can be reached in that position before making a choice.

Level the appliance by acting on the individual feet.

! This appliance can only be installed and operate in rooms which are permanently ventilated, in order to guarantee correct operation.

i Connect and leave for a certain period of time (at least 2 hours) before checking functioning. During transport it is probable that the compressor lubricant oil has entered the refrigerant circuit blocking the capillary: as a consequence the appliance will function for a certain period of time without producing cold until the oil has returned to the compressor.

! **ATTENTION:** the appliance requires the minimum functioning spaces, as shown in the attachments.

The defrosting water and the water that forms at the bottom of the refrigerating compartment during operation or during periodical internal cleaning must be drained through a prearranged hose with a minimum diameter 3/4" connected to the hose at the bottom of the chiller.

A drain trap should also be guaranteed. The drain must be in compliance with Standards in force.

8.3. Electric Power Supply Connection

Connection must be carried out by authorised and qualified staff, respecting the current laws regarding the subject and using appropriate prescribed material.

i Before connecting the appliance to the electric mains, check that the voltage and the frequency correspond to the data stated on the registration plate applied on the rear of the appliance.

i The appliance is supplied with an operating voltage of 230V 1+N~ 50 50Hz. On request, it is

possible to have appliances with different voltages.

! Before connection, ensure the presence of a relevant differential switch with adequate power in the mains power supply, upstream from the appliance, in order to protect the appliance from overloads or short circuits

8.4. Condensing unit water connection

The chiller cabinets with water condensation have been designed to use normal tap water.

Connect the mains pipe to the appliance connection pipe, positioning a shut-off cock (**A**) to interrupt the water supply when necessary. Install some easily reachable filters downstream from this.

i The water pressure must be between 150÷300 kPA (1.5÷3 bar).

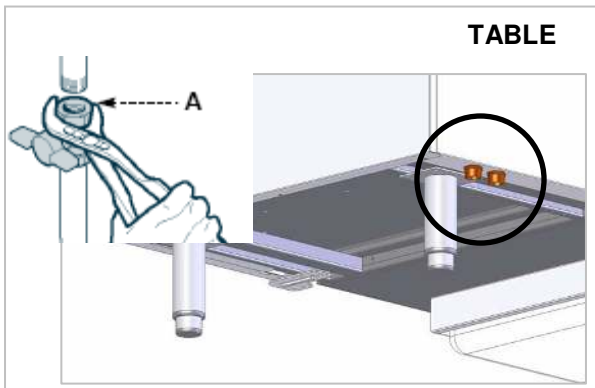
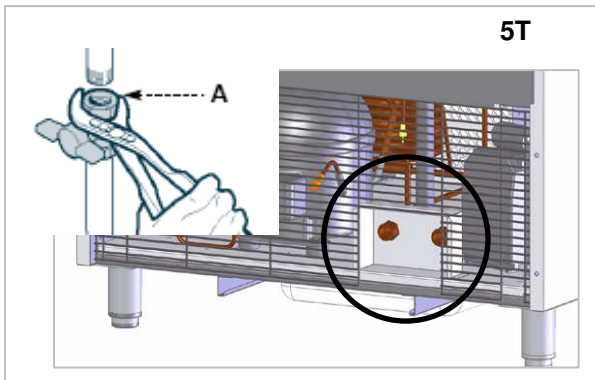

! Attachment to the water network must be carried out before switching the appliance on: if cooling is missing from the condensing circuit, the maximum pressure switch intervenes, which blocks the machine.

The machine must also be checked for leaks that could interfere with electrical parts and cause short-circuits.

It is preferable for both the water drain and supply pipes to be fitted with cocks to stop the water supply to the machine during maintenance.

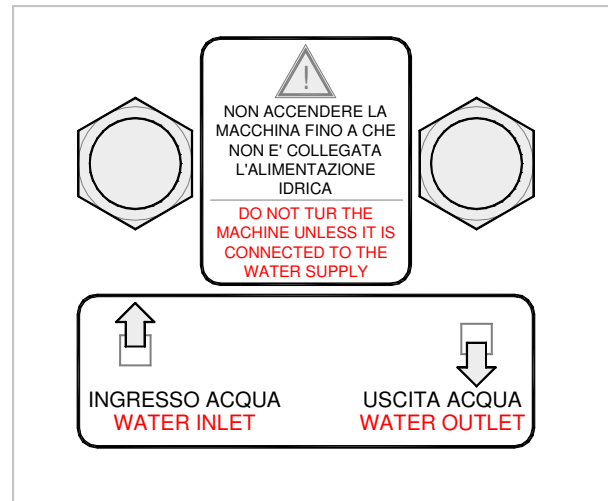

Both water inlet and drain pipe connections are 3/4". To know which attachment to use (both 3/4"), simply follow the indications in the figure (the same label should be found near the water supply connections).

i If the water has a high mineral salt content (i.e. if it is too hard), to ensure long and efficient life to the exchanger we suggest you install a water softener at the water inlet.

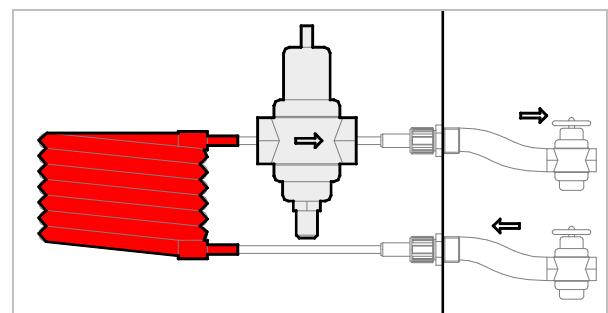

Even if the pressure valve has been calibrated before leaving the factory, after having connected the machine to the water supply and turned on the any cocks installed, check for water leaks from the drain when the machine is at a standstill. In case of a leak, adjust the pressure valve until the leak stops.

8.5. Inspection

The appliance is delivered in conditions such that it can be started-up by the user.

This functionality is guaranteed by passing the tests (electric inspection - functional inspection, appearance inspection) and relative certification through the specific attachments.

At least the following should be checked after installation:

- Check the electric connections.
- Check the functionality and efficiency of drains.
- Check that there are no tools or materials left in the appliance that could jeopardise its functionality or even damage the machine.
- Have the appliance perform at least one complete chill blasting/shock freezing cycle









8.6. Parameters Programming

Access to the programming procedure of the configuration parameters is admitted only with machine at standstill. There are two levels of configuration present.

Level 0 (USER)













USER parameters directly amendable from keyboard (example blast chilling time).

To access such parameters carry out the following:

- ❖ Press  for at least three seconds, the upper display shows parameter **PA**;
 - ❖ scroll the parameters using keys  and  : the top part displays the name of the parameter, the bottom part the value.
 - ❖ to amend the displayed parameter, press  : the parameter displayed in the bottom part flashes.
 - ❖ press keys  and  to amend the parameter value, press  to memorise the new value;
 - ❖ continue in this way to amend the other parameters;
- To exit programming, press for at least 5 seconds key  or await one minute without pressing any key.

Level 1 (INSTALLER)

To access all parameters, carry out the following:

- ❖ Press  for at least three seconds, the upper display shows parameter **PA**;
 - ❖ press  to set the password: the parameter displayed in the bottom part flashes.
 - ❖ press keys  and  to select the password value -19.
 - ❖ confirm data by pressing  : the first parameter is shown on display;
 - ❖ scroll the parameters using keys  and  : the top part displays the name of the parameter, the bottom part the value.
 - ❖ to amend the displayed parameter, press  : the parameter displayed in the bottom part flashes.
 - ❖ press keys  and  to amend the parameter value, press  to memorise the new value;
 - ❖ continue in this way to amend the other parameters;
- To exit programming, press for at least 5 seconds key  or await one minute without pressing any key.

To print the parameters, keep key  pressed for 3 seconds.

9. DISPOSAL OF THE APPLIANCE

i This appliance is marked in compliance with the 2002/96/EC European Directive, WASTE ELECTRICAL AND ELECTRONIC EQUIPMENT (WEEE).

! By assuring that this product is disposed of correctly, the user contributes to preventing the potential negative consequences on the environment and health.



The symbol found on the product or on the accompanying documentation indicates

that this product must not be treated as domestic waste but must be taken to suitable collection points for the recycling of electric and electronic appliances.

Dispose of it following local regulations regarding waste disposal.

For further information regarding the treatment, recovery and recycling of this product, contact the relevant local office, the domestic waste collection service or the shop where the product was purchased.

10. REFRIGERANT TECHNICAL CARD

The refrigerant used in the machine is R404a fluid. Below find the components of the fluid:

PENTAFLUOROETHANE (HFC R125) 44%
 ETHANE 1,1,1 – TRIFLUORO (HFC R143A) 52%
 ETHANE 1,1,1,2 TETRAFLUORO (HFC R134A) 4%

IDENTIFICATION OF DANGERS

The rapid evaporation of the liquid can cause freezing. The inhalation of high concentrations of vapour can cause irregular heartbeat, short term narcotic effects (including vertigo, headache and mental confusion), fainting and death.

- Effects to the eyes: Freezing or cold burns caused by contact with the liquid.
- Effects on the skin: Freezing or cold burns caused by contact with the liquid.

- Effects of ingestion. Ingestion is not considered a means of exposure

FIRST AID

Eyes: In the case of contact, wash the eye well using a large amount of water for at least 15 minutes. Consult a doctor.

Effects on the skin: Wash with water for at least 15 minutes after excessive contact. If necessary, cure freezing by gently warming the area in question. Consult a doctor in the case of irritation.

Ingestion: Ingestion is not considered a means of exposure.

Inhalation: If large concentrations are inhaled, go into the open air. Keep the person calm. If the person cannot breathe, perform artificial respiration. If respiration is difficult, apply oxygen. Consult a doctor.

retigo®

RETIGO
Láň 2310, PS43
756 64 Rožnov pod Radhoštěm
email: info@retigo.cz
tel.: +420 571 665 511