

Apach
BAKERY *Line*

FORNO ROTATIVO

ROTARY RACK OVEN

FOUR ROTATIF

HORNO ROTATIVO

J series



J_E



J_C

MANUALE RICAMBI
SPARE PARTS MANUAL
CATALOGUE DES PIECES DE RECHANGE
LISTA REPUESTOS

REV.A

Sommario

Descrizione Generale	5
Versione con scambiatore laterale a Combustione	5
Version with combustion side heat exchanger.....	6
Version avec échangeur lateral à combustion	6
Version con intercambiador lateral de combustion	6
Versione con Scambiatore Laterale a Combustione	7
Versione con Scambiatore Elettrico.....	7
Scambiatore a Combustione.....	8
Scambiatore Elettrico	8
IT Ventilatore di Cottura.....	9
ENG Baking fan.....	9
FR Ventilateur de cuisson	9
ES Ventilador de cocción.....	9
IT Aspiratore Vapori.....	10
ENG Steam exhauster	10
FR Aspirateur de vapeur	10
ES Aspirador de vapor	10
IT Valvola di Scarico Vapori Manuale	11
ENG Manual fume exhaust valve	11
FR Soupape manuale de décharge fumes	11
ES Valvula manual de escape humos	11
IT Valvola di Scarico Vapori Automatica	12
ENG Automatic fume exhaust valve	12
FR Soupape automatique de décharge fumes	12
ES Valvula automática de escape humos.....	12
IT Gruppo Motoriduttore Standard	13
ENG Standard gear motor group	14
FR Groupe standard du moteur réducteur.....	14
ES Grupo estándar del motor reductor.....	14
IT Gruppo Motoriduttore con Sollevatore Automatico	15
ENG Gear motor group with automatic lifter	16
FR Groupe moteur reducteur avec dispositif de levage automatique	16
ES Grupo motor reductor con elevador automático.....	17
IT Gruppo Piattaforma Girevole	18
ENG Turntable group.....	19
FR Groupe de la plaque tournante	19
ES Grupo de la plataforma giratoria	19
IT Perno inferiore rotazione carrello.....	20
ENG Lower pin for rack's rotation	20
FR Axe inférieur pour la rotation du chariot.....	20
ES Pivote bajo por la rotación del carro	20
IT Camera di combustione	22
ENG Combustion chamber	22
FR Chambre de combustion.....	22
ES Cámara de combustión	22
IT Bruciatori.....	23
ENG Burners.....	23
FR Brûleurs	24
ES Quemadores.....	24
IT Resistenze Elettriche	26
ENG Electric resistors.....	26

FR Chauffages électriques	26
ES Resistencias eléctricas	26
IT Gruppo Vaporiera.....	27
ENG Steam generator's group	28
FR Groupe générateur de vapeur	28
ES Grupo generador de vapor	28
IT Porta della Camera di Cottura	30
ENG Baking chamber's door	30
FR Porte de la chambre de cuisson	30
ES Puerta de la cámara de cocción	30
IT Gruppo maniglia porta	31
ENG Door handle's group	31
FR Groupe poignée porte	32
ES Grupo manilla de la puerta	32
IT Cerniere della Porta	34
ENG Door's hinges	34
FR Charnières porte	34
ES Bisagras de puerta	34
IT Pannello comandi digitale per versioni a combustione	36
ENG Digital control panel for combustion versions	36
FR Tableau de bord digital pour versions à combustion.....	36
ES Panel de mando digital por versiones a combustion	36
IT Pannello comandi digitale per versioni elettriche	38
ENG Digital control panel for electric versions.....	38
FR Tableau de bord digital pour versions électriques.....	38
ES Panel de mando digital por versiones eléctricas.....	38
IT Pannello Comandi Elettromeccanico	40
ENG Electromechanical control panel.....	40
FR Tableau de bord électromécanique.....	40
ES Panel de mando electromecánico	40
IT Termocoppia e Termostati di Sicurezza.....	41
ENG Thermocouple and safety thermostats	41
FR Thermocouple et thermostats de sécurité.....	41
ES Termopar y termostatos de seguridad	41
IT Finecorsa	42
ENG Limit switch	42
FR Fin de course	42
ES Final de carrera.....	42
IT Portalampade	Errore. Il segnalibro non è definito.
ENG Lamp holders	Errore. Il segnalibro non è definito.
Description	Errore. Il segnalibro non è definito.
FR Porte-lampes.....	Errore. Il segnalibro non è definito.
Description	Errore. Il segnalibro non è definito.
ES Portalámparas	Errore. Il segnalibro non è definido.
Descripción	Errore. Il segnalibro non è definido.
IT Portalampade	44
ENG Lamp holders	44
FR Porte-lampes.....	44
ES Portalámparas	44
IT Elettrovalvola e Gruppo Acqua.....	45
ENG Electrovalve and water group	45
FR Electrovanne et groupe eau	45
ES Electroválvula y grupo agua.....	45
IT Maniglia Porta Comandi	46
ENG Control door's handle	46

FR Poignée porte de commande	46
ES Manilla puerta de control	46
IT Visualizzatore Cappa.....	47
ENG Hood's display	47
FR Écran hotte	47
ES Pantalla de la campana	47
IT Isolamento	48
ENG Isolation	48
FR Insulation.....	48
ES Aislamiento	48
IT Accessori	49
ENG Accessories	49
FR Accessoires.....	49
ES Accesorios	49

Descrizione Generale

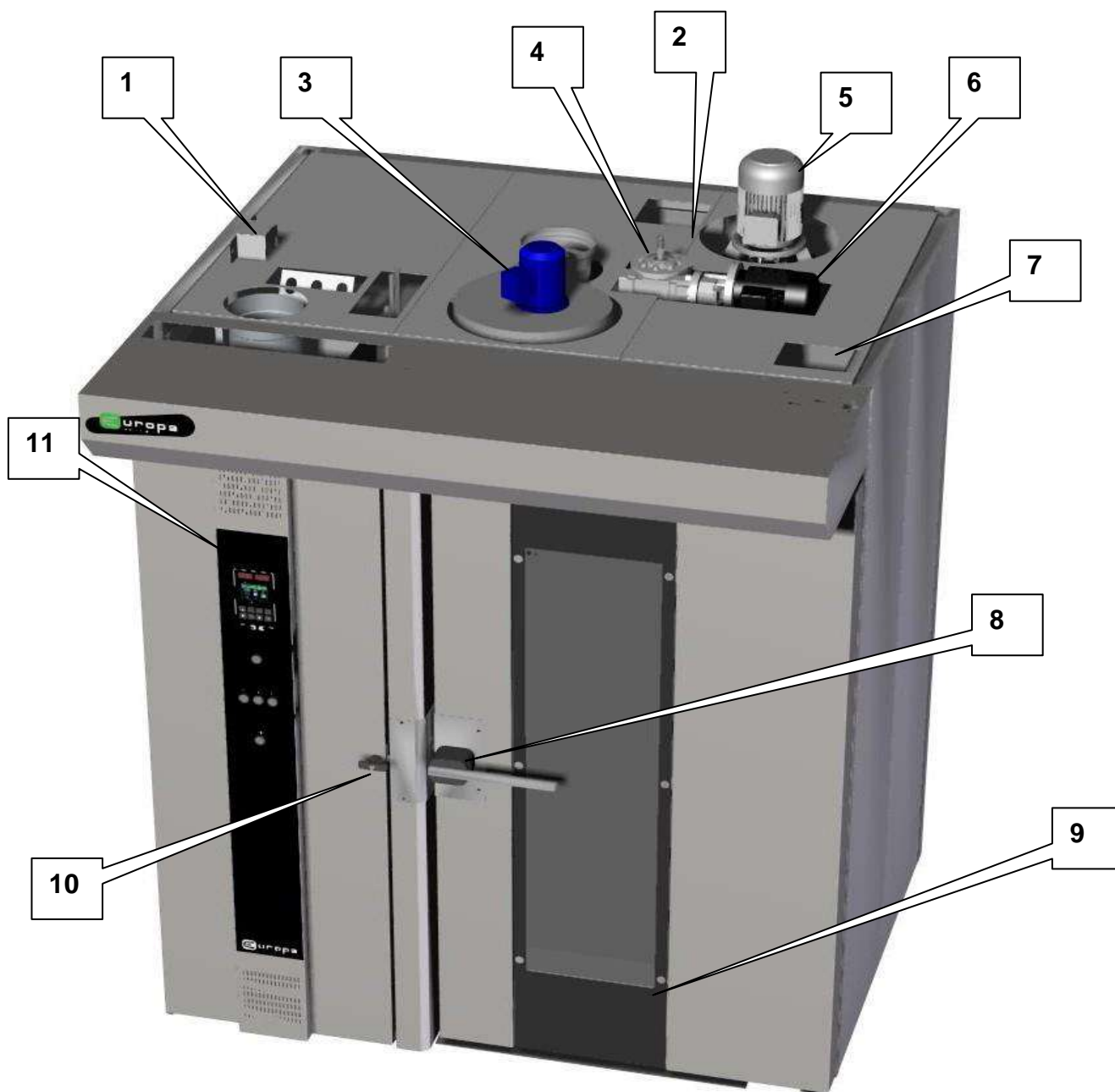

IT	Versione con scambiatore laterale a Combustione
1.	Doppia Elettrovalvola acqua vaporiera e termostati di sicurezza
2.	Termocoppia di rilievo temperatura
3.	Aspiratore vapori
4.	Finecorsa di fermata in posizione del carrello
5.	Ventilatore di cottura
6.	Motoriduttore per la rotazione del carrello
7.	Finecorsa porta con comando a camma
8.	Maniglia della porta
9.	Vetro esterno porta apribile
10.	Maniglia della porta comandi (solo per versioni Laterali)
11.	Pannello di comando e controllo

ENG	Version with combustion side heat exchanger
1.	Steam generator's double water electrovalve and safety thermostats
2.	Thermocouple for temperature detection
3.	Steam exhauster
4.	Stop limit switch in rack's position
5.	Baking fan
6.	Gear motor for rack's rotation
7.	Door's limit switch with cam control
8.	Door's handle
9.	Openable door's exterior glass
10.	Command panel's handle (only for lateral versions)
11.	Control and command panel

FR	Version avec échangeur lateral à combustion
1.	Double électrovalve eau de générateur vapeur et thermostats de sécurité
2.	Thermocouple pour détection température
3.	Aspirateur vapeurs
4.	Interrupteur fin de course en position chariot
5.	Ventilateur de cuisson
6.	Moto réducteur pour rotation chariot
7.	Fin de course porte avec commande à came
8.	Poignée de porte
9.	Verre extérieur de porte ouvrable
10.	Poignée du panneau de commande (seulement pour versions lateraux)
11.	Panneau de commande et contrôle

ES	Version con intercambiador lateral de combustion
1.	Doble electroválvula agua del generador vapor y termostatos de seguridad
2.	Termopar por la detección de temperatura
3.	Aspirador de vapor
4.	Interruptor de posición final del carro
5.	Ventilador de cocción
6.	Motor reductor por rotation del carro
7.	Interruptor fin de carrerade la puerta con control por levas
8.	Maneta de la puerta
9.	Vidrio exterior de la puerta abrible
10.	Maneta de la puerta de mando (únicamente por versiones laterales)
11.	Panel de mando y control

Versione con Scambiatore Laterale a Combustione



Vista Frontale

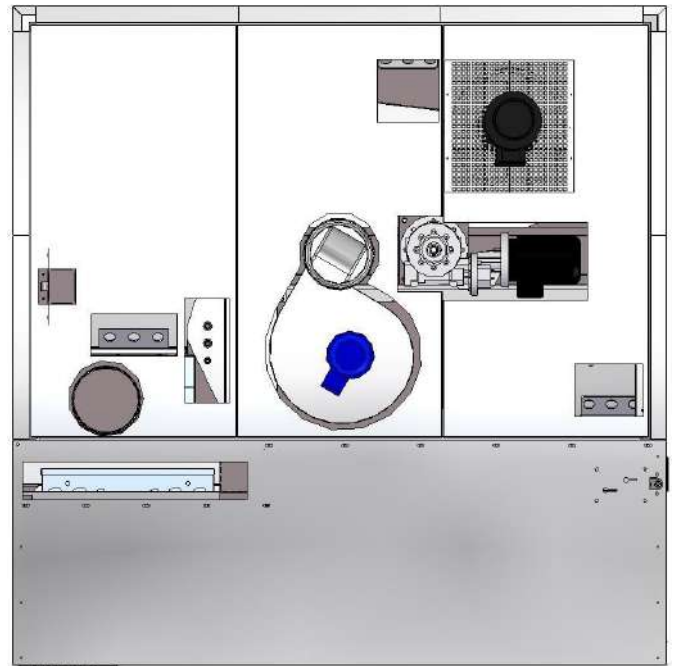

Vista Superiore

Versione con Scambiatore Elettrico



Vista Frontale

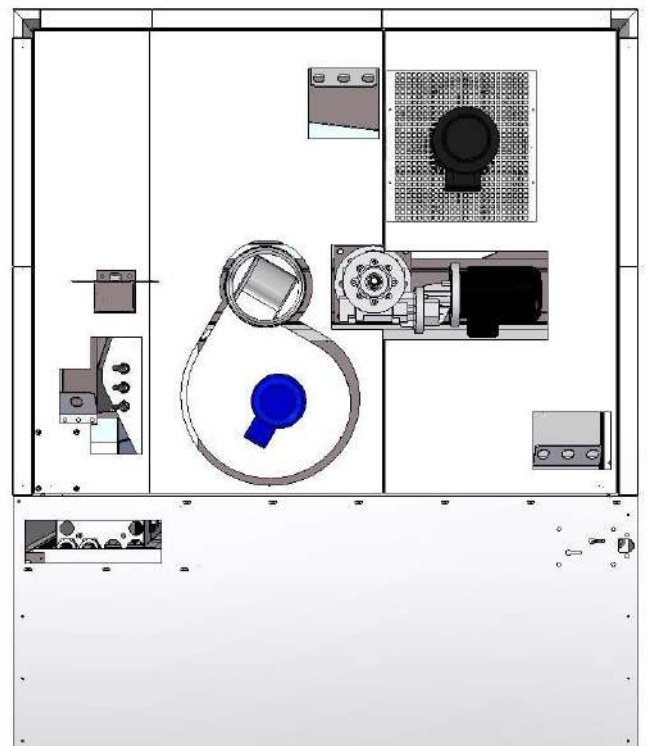

Vista Superiore

Scambiatore a Combustione

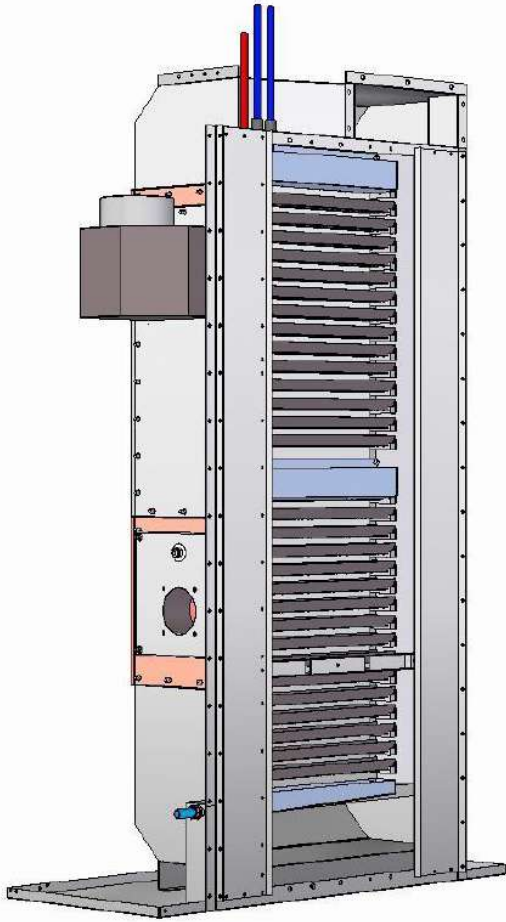

Scambiatore Elettrico

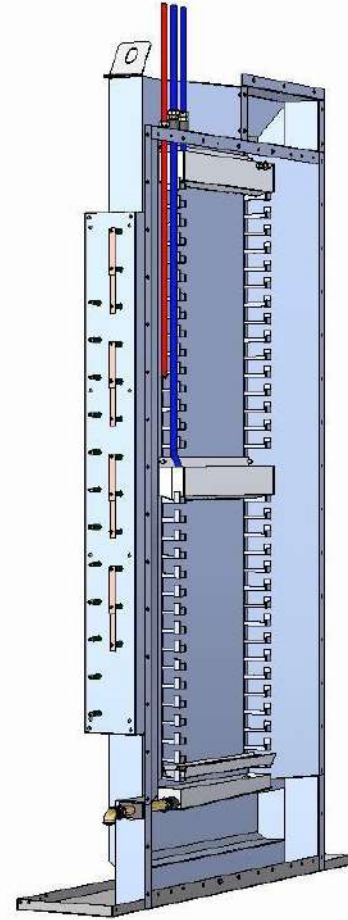

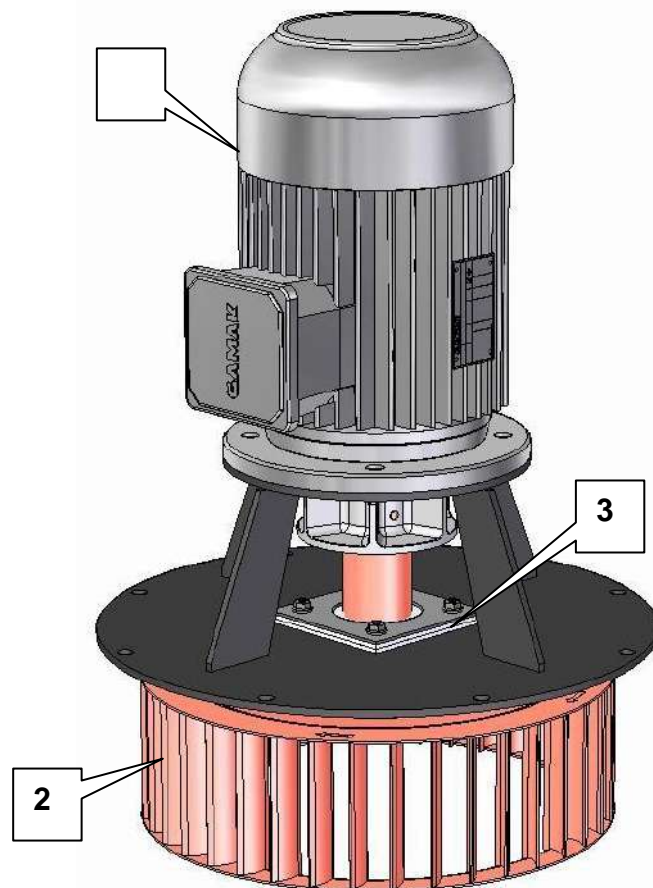

IT Ventilatore di Cottura		
Pos.	Codice	Descrizione
1	31910027	MOTORE 90 H 1,5 KW 4P B5 MF/MT , 1 VELOCITÀ
1	31910025	MOTORE 90 H 1,5/0,55 KW 4/6P B5 M/F-M/T , 2 VELOCITÀ
2	31900087	GIRANTE A 50 HZ
2	31900088	GIRANTE A 60 HZ
3	43000031	GUARNIZIONI IN SILICONE

ENG Baking fan		
Pos.	Code	Description
1	31910027	ENGINE 90 H 1,5 KW 4P B5 MF/MT - 1 VELOCITY
1	31910025	ENGINE 90 H 1,5/0,55 KW 4/6P B5 M/F-M/T - 2 VELOCITY
2	31900087	50 HZ IMPELLER
2	31900088	60 HZ IMPELLER
3	43000031	SILICONE GASKETS

FR Ventilateur de cuisson		
Pos.	Code	Description
1	31910027	MOTEUR 90 H 1,5 KW 4P B5 MF/MT - 1 VITESSE
1	31910025	MOTEUR 90 H 1,5/0,55 KW 4/6P B5 M/F-M/T - 2 VITESSE
2	31900087	50 HZ POMPE
2	31900088	60 HZ POMPE
3	43000031	JOINTS EN SILICONE

ES Ventilador de cocción		
Pos.	Código	Descripción
1	31910027	MOTOR 90 H 1,5 KW 4P B5 MF/MT - 1 VELOCIDAD
1	31910025	MOTOR 90 H 1,5/0,55 KW 4/6P B5 M/F-M/T - 2 VELOCIDAD
2	31900087	50 HZ IMPULSOR
2	31900088	60 HZ IMPULSOR
3	43000031	JUNTAS DE SILICONA

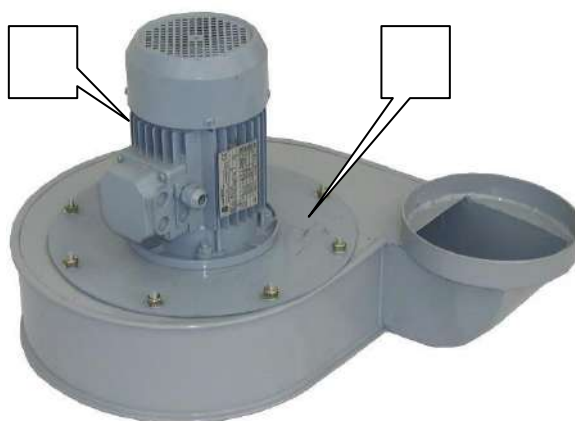

IT Aspiratore Vapori		
Pos.	Codice	Descrizione
1	31910040	MOTORE 71 F 0,37 KW 4P B5 NOR/UL (USA - CANADA)
1	31910021	MOTORE 71 F 0,37 KW 4P B5 230/400V (VERSIONE STANDARD)
1	31910037	MOTORE 71 F 0,37 KW 4P B5 208/360V 60 HZ (VERSIONE A 60 HZ)
2	31900031	ASPIRATORE COMPLETO ECB/M 250 0,37 KW 4P 230/400V 50HZ

ENG Steam exhauster		
Pos.	Code	Description
1	31910040	ENGINE 71 F 0,37 KW 4P B5 NOR/UL (USA - CANADA)
1	31910021	ENGINE 71 F 0,37 KW 4P B5 230/400V (STANDARD VERSION)
1	31910037	ENGINE 71 F 0,37 KW 4P B5 208/360V 60 HZ (60 HZ VERSION)
2	31900031	COMPLETE EXHAUSTER ECB/M 250 0,37 KW 4P 230/400V 50HZ

FR Aspirateur de vapeur		
Pos.	Code	Description
1	31910040	MOTEUR 71 F 0,37 KW 4P B5 NOR/UL (USA - CANADA)
1	31910021	MOTEUR 71 F 0,37 KW 4P B5 230/400V (VERSION STANDARD)
1	31910037	MOTEUR 71 F 0,37 KW 4P B5 208/360V 60 HZ (VERSION 60 HZ)
2	31900031	ASPIRATEUR COMPLET ECB/M 250 0,37 KW 4P 230/400V 50HZ

ES Aspirador de vapor		
Pos.	Código	Descripción
1	31910040	MOTOR 71 F 0,37 KW 4P B5 NOR/UL (USA - CANADA)
1	31910021	MOTOR 71 F 0,37 KW 4P B5 230/400V (VERSION ESTANDAR)
1	31910037	MOTOR 71 F 0,37 KW 4P B5 208/360V 60 HZ (60 HZ VERSION)
2	31900031	ASPIRADOR COMPLETO ECB/M 250 0,37 KW 4P 230/400V 50HZ

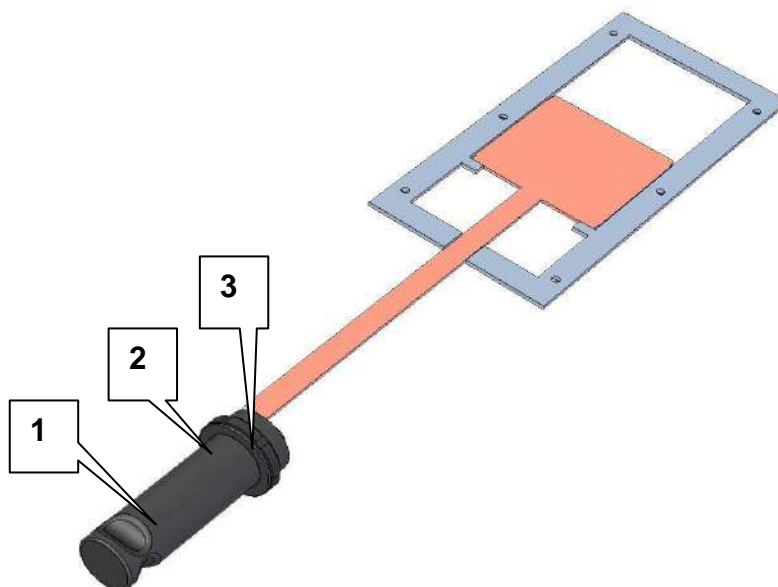

IT Valvola di Scarico Vapori Manuale

Pos.	Codice	Descrizione
1	44000026	MANIGLIA TIRANTE
2	44000025	BOCCOLA ESTERNA
3	44000029	GHIERA DI FISSAGGIO

ENG Manual fume exhaust valve

Pos.	Code	Description
1	44000026	PULL HANDLE
2	44000025	OUTER BUSHING
3	44000029	FASTENING RING

FR Soupape manuelle de décharge fumes

Pos.	Code	Description
1	44000026	POIGNEE DE TIRAGE
2	44000025	DOUILLE EXTERIEURE
3	44000029	BAGUE DE SERRAGE

ES Valvula manual de escape humos

Pos.	Código	Descripción
1	44000026	MANIJA DE TIRO
2	44000025	CASQUILLO EXTERIOR
3	44000029	ANILLO DE FIJACION

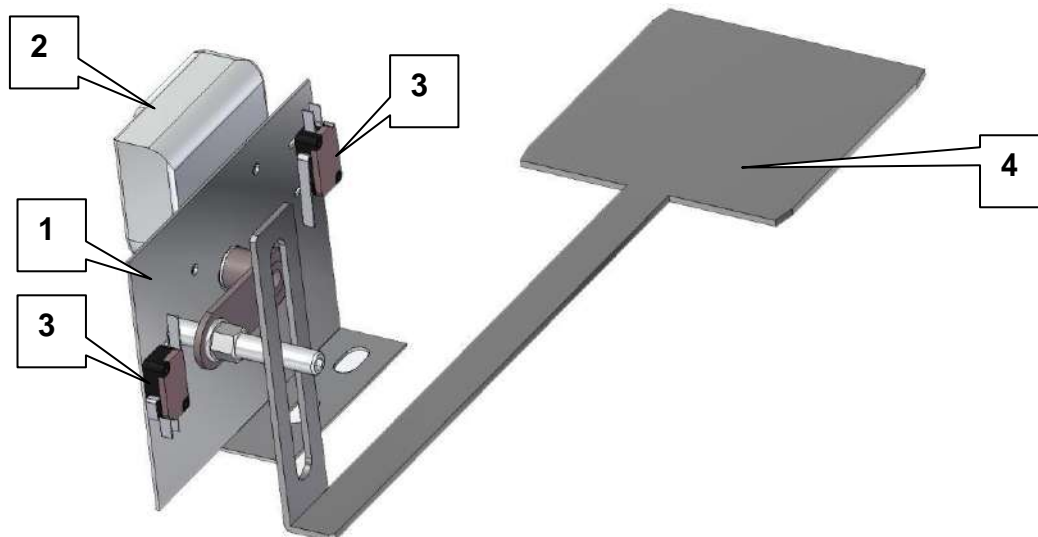

IT Valvola di Scarico Vapori Automatica		
Pos.	Codice	Descrizione
1	61002372	GRUPPO MOTORIDUTTORE COMPLETO DI FINECORSA
2	31920011	MOTORIDUTTORE 45.K60 , 12NM , 6 RPM
3	39970010	FINECORSA 5A 250V MINIATURA
4	21007858	SERRANDA VALVOLA AUTOMATICA

ENG Automatic fume exhaust valve		
Pos.	Code	Description
1	61002372	GEAR MOTOR WITH LIMIT SWITCH
2	31920011	GEAR MOTOR 45.K60, 12NM, 6 RPM
3	39970010	LIMIT SWITCH 5A 250V MINIATURE
4	21007858	AUTOMATIC VALVE DAMPER

FR Soupape automatique de décharge fumes		
Pos.	Code	Description
1	61002372	MOTO REDUCTOR AVEC INTERRUPTEUR FIN DE COURSE
2	31920011	MOTO REDUCTOR 45.K60 , 12NM , 6 RPM
3	39970010	FIN DE COURSE 5A 250V MINIATURE
4	21007858	LEVIER DE VALVE AUTOMATIQUE

ES Valvula automática de escape humos		
Pos.	Código	Descripción
1	61002372	MOTOR REDUCTOR CON INTERRUPTOR DE POSICION FINAL
2	31920011	MOTOR REDUCTOR 45.K60 , 12NM , 6 RPM
3	39970010	INTERRUPTOR DE POSICION FINAL 5A 250V MINIATURA
4	21007858	PALANCA DE VÁLVULA AUTOMÁTICA

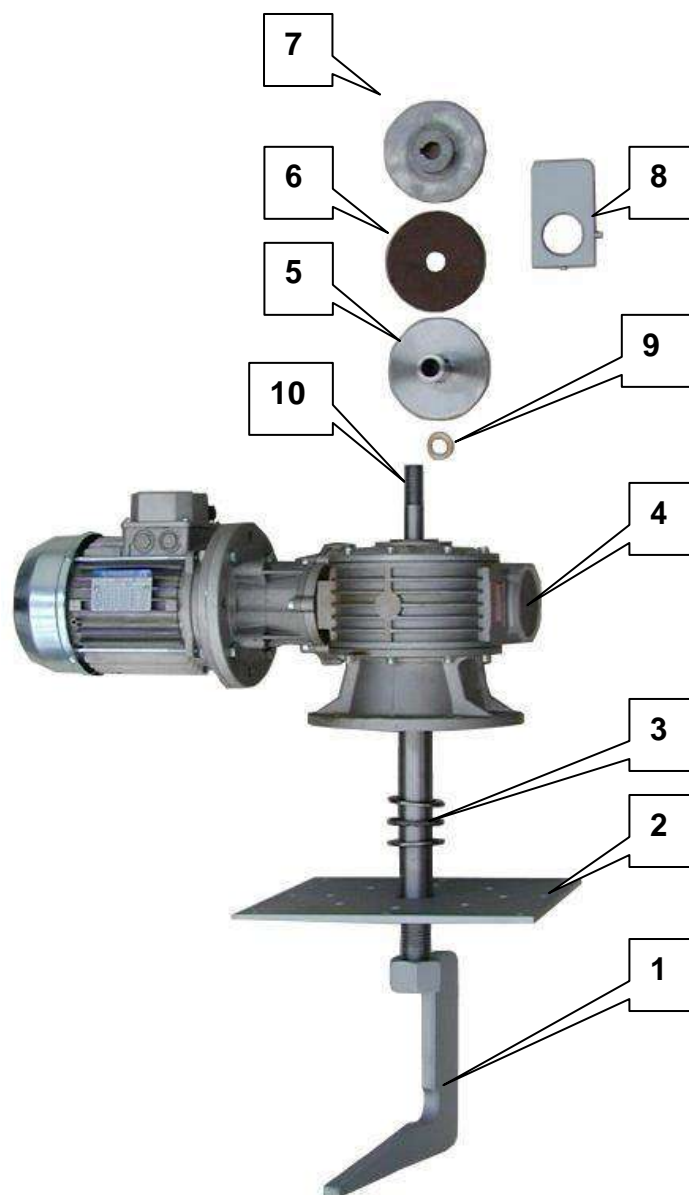

IT Gruppo Motoriduttore Standard		
Pos.	Codice	Descrizione
1	61001982	GANCIO PER CARRELLO ALTO (H = 1950)
1	61002133	GANCIO PER CARRELLO BASSO (H = 1810)
2	21007640	PIASTRA SUPPORTO MOTORIDUTTORE CARRELLO
3	57900001	CUSCINETTO ASSIALE 51107 (35X52X12)
4	31920020	MOTORIDUTTORE
5	25000163	FRIZIONE INFERIORE MOTORIDUTTORE CARRELLO
6	43900041	DISCO FRIZIONE DIAMETRO 98MM
7	25000164	FRIZIONE SUPERIORE MOTORIDUTTORE CARRELLO
8	23000111	CAMMA FINECORSA CARRELLO
9	21002208	RONDELLA BRONZO (25X18X2)
10	25000672	ALBERO MOTORIDUTTORE CARRELLO
	61002037	MOTORIDUTTORE COMPLETO

ENG Standard gear motor group		
Pos.	Code	Description
1	61001982	HOOK FOR HIGH RACK (H = 1950)
1	61002133	HOOK FOR LOW RACK (H = 1810)
2	21007640	SUPPORTING PLATE FOR GEAR MOTOR RACK
3	57900001	AXIAL BEARING 51107 (35X52X12)
4	31920020	GEAR MOTOR
5	25000163	LOWER FRICTION GEAR MOTOR RACK
6	43900041	DISK CLUTCH DIAMETER 98MM
7	25000164	SUPERIOR FRICTION GEAR MOTOR RACK
8	23000111	CAM LIMIT SWITCH RACK
9	21002208	BRONZE WASHER (25X18X2)
10	25000672	SHAFT GEAR MOTOR RACK
	61002037	COMPLETE GEAR MOTOR

FR Groupe standard du moteur réducteur		
Pos.	Code	Description
1	61001982	CROCHET HAUT CHARIOT (H = 1950)
1	61002133	CROCHET BAS CHARIOT (H = 1810)
2	21007640	PLAQUE SUPPORT POUR MOTEUR REDUCTEUR
3	57900001	PALIER AXIAL 51107 (35X52X12)
4	31920020	MOTEUR REDUCTEUR
5	25000163	FRICTION INFERIEURE CHARIOT MOTEUR REDUCTEUR
6	43900041	DISQUE A FRICTION DIAMETRE 98MM
7	25000164	FRICTION SUPERIEURE CHARIOT MOTEUR REDUCTEUR
8	23000111	CAME FIN DE COURSE CHARIOT
9	21002208	RONDELLE DE BRONZE (25X18X2)
10	25000672	ARBRE CHARIOT MOTEUR REDUCTEUR
	61002037	MOTEUR REDUCTEUR COMPLET

ES Grupo estándar del motor reductor		
Pos.	Código	Descripción
1	61001982	GANCHO CARRO ALTO (H = 1950)
1	61002133	GANCHO CARRO BAJO (H = 1810)
2	21007640	PLACA PORTADORA DEL MOTOR REDUCTOR
3	57900001	COJINETE AXIAL 51107 (35X52X12)
4	31920020	MOTOR REDUCTOR
5	25000163	FRICCION INFERIORA DEL CARRO DEL MOTOR REDUCTOR
6	43900041	DISCO DE FRICCION DIAMETRO 98MM
7	25000164	FRICCION SUPERIORA DEL CARRO DEL MOTOR REDUCTOR
8	23000111	LEVA FINAL DE RECORRIDO CARRO
9	21002208	ARANDELA DE BRONCE (25X18X2)
10	25000672	EJE CARRO MOTOR REDUCTOR
	61002037	MOTOR REDUCTOR COMPLETO

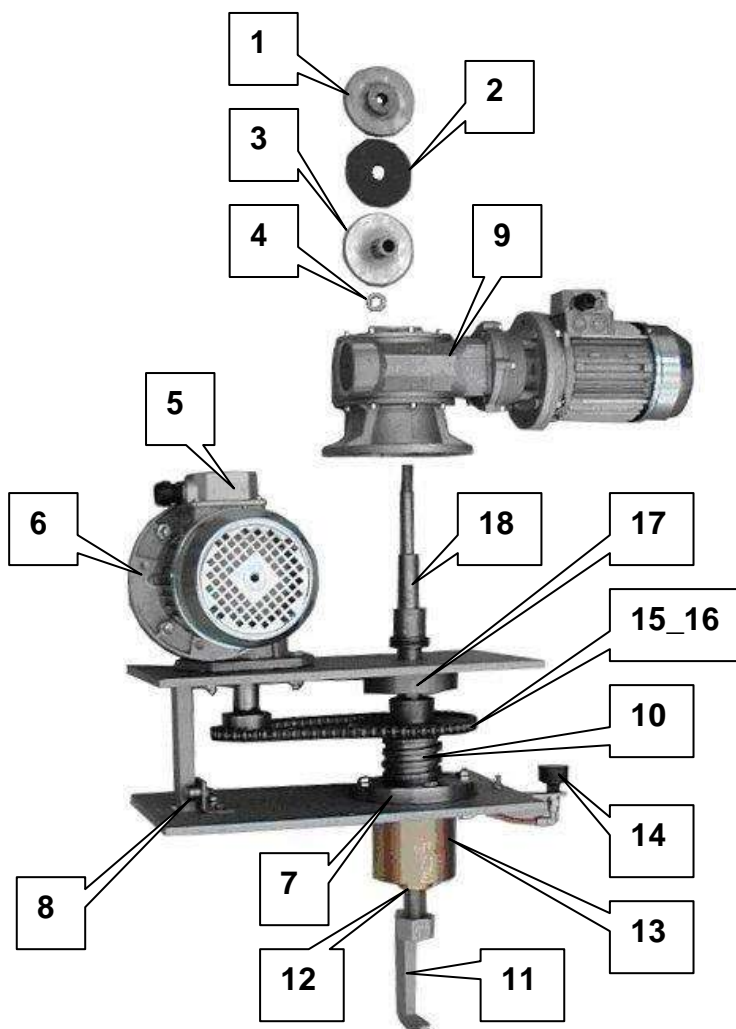

IT Gruppo Motoriduttore con Sollevatore Automatico		
Pos.	Codice	Descrizione
1	25000164	FRIZIONE SUPERIORE MOTORIDUTTORE CARRELLO
2	43900041	DISCO FRIZIONE DIAMETRO 98MM
3	25000163	FRIZIONE INFERIORE MOTORIDUTTORE CARRELLO
4	21002208	RONDELLA BRONZO (25X18X2)
5	31910022	MOTORE 80 H 0.55 KW 4P B5 MF/MT
6	31920012	RIDUTTORE FRS60/FL V1I 1/28 IEC80
7	57900001	CUSCINETTO ASSIALE 51107 (35X52X7)
8	57900007	CUSCINETTO RADIALE UNA CORONA SFERE (8X22X7)
9	31920020	MOTORIDUTTORE COMPLETO
10	25000183	VITE SOLLEVATORE AUTOMATICO
11	23000120	GANCIO SOLLEVATORE AUTOMATICO CARRELLO
12	27000010	GUIDA ALBERO SU VITE SOLLEVATORE AUTOMATICO
13	25000181	MADREVITE SOLLEVATORE AUTOMATICO
14	55900064	INGRASSATORE STAUFFER ¼" N°4
15	54900038	CATENA ½"X5/16" NERA
16	54900039	GIUNTO CATENA ½"X5/16"
17	57900008	CUSCINETTO RADIALE UNA CORONA SFERE (60X95X18)
18	25000182	ALBERO MOTORIDUTTORE SOLLEVATORE AUTOMATICO FINITO
	31920037	SOLLEVATORE AUTOMATICO COMPLETO

ENG Gear motor group with automatic lifter		
Pos.	Code	Description
1	25000164	UPPER FRICTION GEAR MOTOR RACK
2	43900041	DISK CLUTCH DIAMETER 98MM
3	25000163	LOWER FRICTION GEAR MOTOR RACK
4	21002208	BRONZE WASHER (25X18X2)
5	31910022	MOTOR 80 H 0.55 KW 4P B5 MF/MT
6	31920012	REDUCER FRS60/FL V11 1/28 IEC80
7	57900001	AXIAL BEARING 51107 (35X52X7)
8	57900007	RADIAL BEARING SINGLE-ROW BALL (8X22X7)
9	31920020	COMPLETE GEAR MOTOR
10	25000183	SCREW AUTOMATIC LIFTER
11	23000120	HOOK AUTOMATIC LIFTER RACK
12	27000010	RAIL SHAFT SCREW AUTOMATIC LIFTER
13	25000181	SPINDLE-NUT AUTOMATIC LIFTER
14	55900064	OILER STAUFFER ¼" N°4
15	54900038	CHAIN ½"X5/16" BLACK
16	54900039	CHAIN SPLIT LINK ½"X5/16"
17	57900008	RADIAL BEARING SINGLE-ROW BALL (60X95X18)
18	25000182	SHAFT MOTOR GEAR AUTOMATIC LIFTER COMPLETE
	31920037	AUTOMATIC LIFTER COMPLETE

FR Groupe moteur reducteur avec dispositif de levage automatique		
Pos.	Code	Description
1	25000164	FRICTION SUPERIEURE CHARIOT MOTEUR REDUCTEUR
2	43900041	DISQUE A FRICTION DIAMETRE 98MM
3	25000163	FRICTION INFERIEURE CHARIOT MOTEUR REDUCTEUR
4	21002208	RONDELLE DE BRONZE (25X18X2)
5	31910022	MOTEUR 80 H 0.55 KW 4P B5 MF/MT
6	31920012	REDUCTEUR FRS60/FL V11 1/28 IEC80
7	57900001	PALIER AXIAL 51107 (35X52X7)
8	57900007	PALIER RADIAL A UNE RANGEE A BILLES (8X22X7)
9	31920020	MOTEUR REDUCTEUR COMPLET
10	25000183	VIS DISPOSITIF LEVAGE AUTOMATIQUE
11	23000120	CROCHET CHARIOT DISPOSITIF LEVAGE AUTOMATIQUE
12	27000010	RAIL ARBRE VIS DE DISPOSITIF LEVAGE AUTOMATIQUE
13	25000181	ECROU D'AXE DISPOSITIF LEVAGE AUTOMATIQUE
14	55900064	GRAISSEUR STAUFFER ¼" N°4
15	54900038	CHAINE ½"X5/16" NOIRE
16	54900039	CHAINON DIVISE ½"X5/16"
17	57900008	PALIER RADIAL A UNE RANGEE A BILLES (60X95X18)
18	25000182	ARBRE MOTEUR REDUCTEUR DU DISPOSITIF LEVAGE AUTOMATIQUE COMPLET
	31920037	DISPOSITIF LEVAGE AUTOMATIQUE COMPLET

ES Grupo motor reductor con elevador automático		
Pos.	Código	Descripción
1	25000164	FRICCION SUPERIORA CARRO MOTOR REDUCTOR
2	43900041	DISCO DE EMBRAGUE DIAMETRO 98MM
3	25000163	FRICCION INFERIORA CARRO MOTOR REDUCTOR
4	21002208	ARANDELA DE BRONCE (25X18X2)
5	31910022	MOTOR 80 H 0.55 KW 4P B5 MF/MT
6	31920012	REDUCTOR FRS60/FL V11 1/28 IEC80
7	57900001	RODAMIENTO AXIAL 51107 (35X52X7)
8	57900007	RODAMIENTO RADIAL A UNA HILERA DE BOLAS (8X22X7)
9	31920020	MOTOR REDUCTOR COMPLETO
10	25000183	TORNILLO ELEVADOR AUTOMATICO
11	23000120	GANCHO DEL CARRO ELEVADOR AUTOMATICO
12	27000010	GUIA EJE TORNILLO ELEVADOR AUTOMATICO
13	25000181	TUERCA HUSILLO ELEVADOR AUTOMATICO
14	55900064	LUBRICADOR STAUFFER ¼" N°4
15	54900038	CADENA ½"X5/16" NEGRA
16	54900039	TELA METALICA SEPARACION ½"X5/16"
17	57900008	RODAMIENTO RADIAL A UNA HILERA DE BOLAS (60X95X18)
18	25000182	EJE MOTOR REDUCTOR ELEVADOR AUTOMATICO COMPLETO
	31920037	ELEVADOR AUTOMATICO COMPLETO

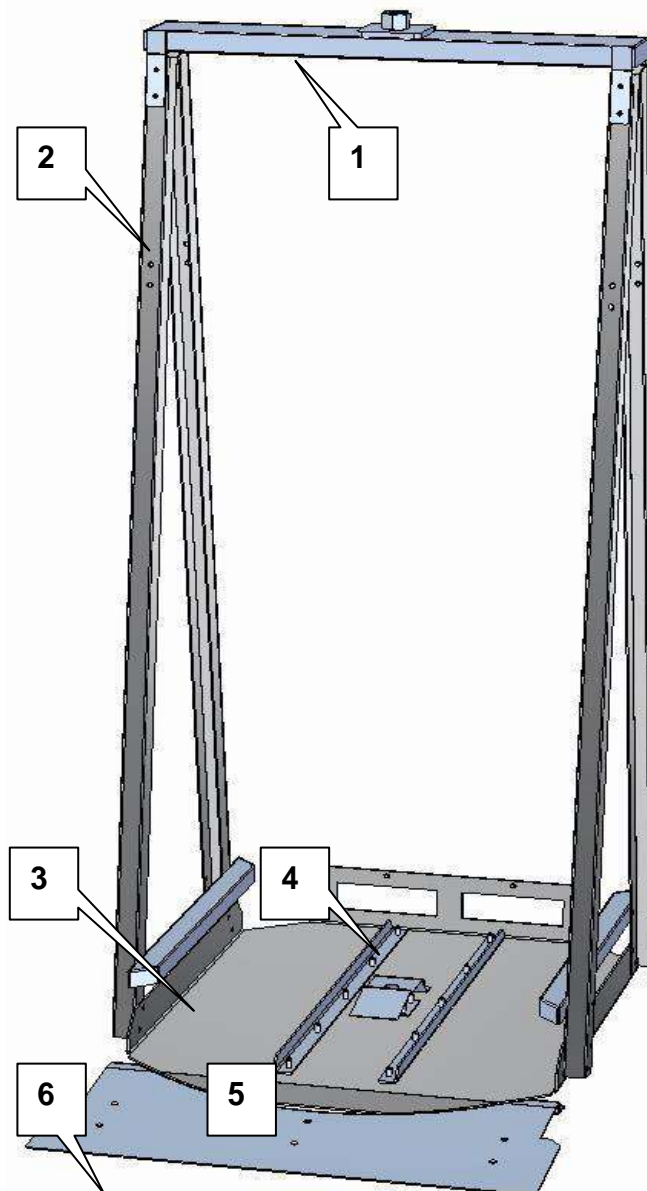

IT Gruppo Piattaforma Girevole		
Pos.	Codice	Descrizione
1	61002041	TRAVERSA SUPERIORE J 108
1	61002087	TRAVERSA SUPERIORE J 128
2	21007865	STAFFE VERTICALI
3	21002340	GUIDE PER INSERIMENTO CARRELLO J 108
3	21002341	GUIDE PER INSERIMENTO CARRELLO J 128
4	21002277	FERMI POSTERIORI CARRELLO
5	21000915	BASE DELLA PIATTAFORMA J 108
5	21000781	BASE DELLA PIATTAFORMA J 128
6	61002042	SCIVOLO FRONTALE DELLA PIATTAFORMA J 108
6	61002090	SCIVOLO FRONTALE DELLA PIATTAFORMA J 128

ENG Turntable group		
Pos.	Code	Description
1	61002041	UPPER CROSSBAR J 108
1	61002087	UPPER CROSSBAR J 128
2	21007865	VERTICAL BRACKETS
3	21002340	RAILS TO INSERT RACK J 108
3	21002341	RAILS TO INSERT RACK J 128
4	21002277	RACK'S REAR RETAINERS
5	21000915	TURNTABLE'S BASE J 108
5	21000781	TURNTABLE'S BASE J 128
6	61002042	J 108 TURNTABLE'S FRONTAL CHUTE
6	61002090	J 128 TURNTABLE'S FRONTAL CHUTE

FR Groupe de la plaque tournante		
Pos.	Code	Description
1	61002041	BARRE SUPERIEURE J 108
1	61002087	BARRE SUPERIEURE J 128
2	21007865	SUPPORTS VERTICAUX
3	21002340	RAILS POUR INSERER LE CHARIOT J 108
3	21002341	RAILS POUR INSERER LE CHARIOT J 128
4	21002277	DISPOSITIFS DE MAINTIEN ARRIERE DU CHARIOT
5	21000915	BASE DE LA PLAQUE TOURNANTE J 108
5	21000781	BASE DE LA PLAQUE TOURNANTE J 128
6	61002042	CHUTE FRONTALE DE LA PLAQUE TOURNANTE J 108
6	61002090	CHUTE FRONTALE DE LA PLAQUE TOURNANTE J 128

ES Grupo de la plataforma giratoria		
Pos.	Código	Descripción
1	61002041	BARRA SUPERIORA J 108
1	61002087	BARRA SUPERIORA J 128
2	21007865	SOPORTES VERTICALES
3	21002340	GUIAS POR INTRODUCIR CARRO J 108
3	21002341	GUIAS POR INTRODUCIR CARRO J 128
4	21002277	RETENEDORES TRASEROS DEL CARRO
5	21000915	BASE DE LA PLATAFORMA J 108
5	21000781	BASE DE LA PLATAFORMA J 128
6	61002042	CANAL FRONTAL DE LA PLATAFORMA J 108
6	61002090	CANAL FRONTAL DE LA PLATAFORMA J 128

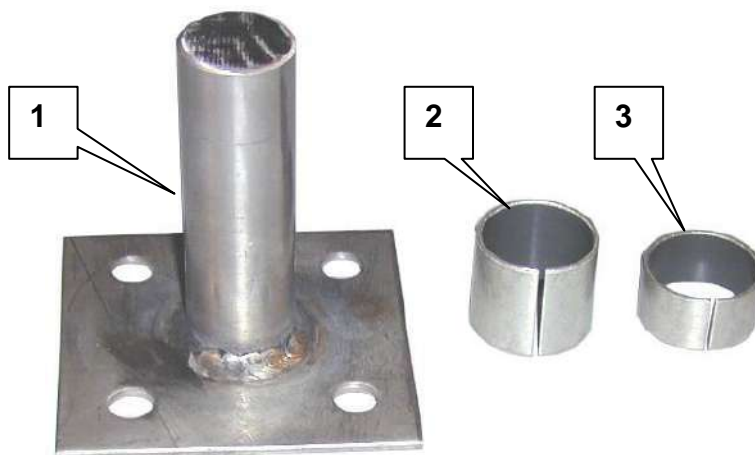

IT Perno inferiore rotazione carrello		
Pos.	Codice	Descrizione
1	26000040	PERNO FLANGIATO ROTAZIONE PIATTAFORMA GIREVOLE ROTOR 99
1	61000499	PERNO FLANGIATO ROTAZIONE CARRELLO DIAMETRO 22
1	26000040	PERNO FLANGIATO ROTAZIONE PIATTAFORMA GIREVOLE
2	57900009	BOCCOLA AUTOLUBRIFICANTE TFP 25/28/25
2	57900018	BOCCOLA AUTOLUBRIFICANTE TFP 22/25/25
3	57900004	BOCCOLA AUTOLUBRIFICANTE TFP 25/28/15

ENG Lower pin for rack's rotation		
Pos.	Code	Description
1	26000040	FLANGED PIN FOR TURNTABLE'S ROTATION ROTOR 99
1	61000499	FLANGED PIN FOR RACK'S ROTATION DIAMETER 22
1	26000040	FLANGED PIN TURNTABLE'S ROTATION
2	57900009	SELF-LUBRICATING BUSHING TFP 25/28/25
2	57900018	SELF-LUBRICATING BUSHING TFP 22/25/25
3	57900004	SELF-LUBRICATING BUSHING TFP 25/28/15

FR Axe inférieur pour la rotation du chariot		
Pos.	Code	Description
1	26000040	AXE A BRIDES POUR ROTATION PLAQUE TOURNANTE ROTOR 99
1	61000499	AXE A BRIDES POUR ROTATION PLAQUE TOURNANTE DIAMETRE 22
1	26000040	AXE A BRIDES POUR ROTATION PLAQUE TOURNANTE
2	57900009	DOUILLES AUTO-LUBRIFIANTES TFP 25/28/25
2	57900018	DOUILLES AUTO-LUBRIFIANTES TFP 22/25/25
3	57900004	DOUILLES AUTO-LUBRIFIANTES TFP 25/28/15

ES Pivote bajo por la rotación del carro		
Pos.	Código	Descripción
1	26000040	PIVOTE EMBRIDADO POR ROTACION PLATAFORMA GIRATORIA ROTOR 99
1	61000499	PIVOTE EMBRIDADO POR ROTACION DIAMETRO 22
1	26000040	PIVOTE EMBRIDADO POR ROTACION PLATAFORMA GIRATORIA
2	57900009	BUJES AUTOLUBRICADOS TFP 25/28/25
2	57900018	BUJES AUTOLUBRICADOS TFP 22/25/25
3	57900004	BUJES AUTOLUBRICADOS TFP 25/28/15

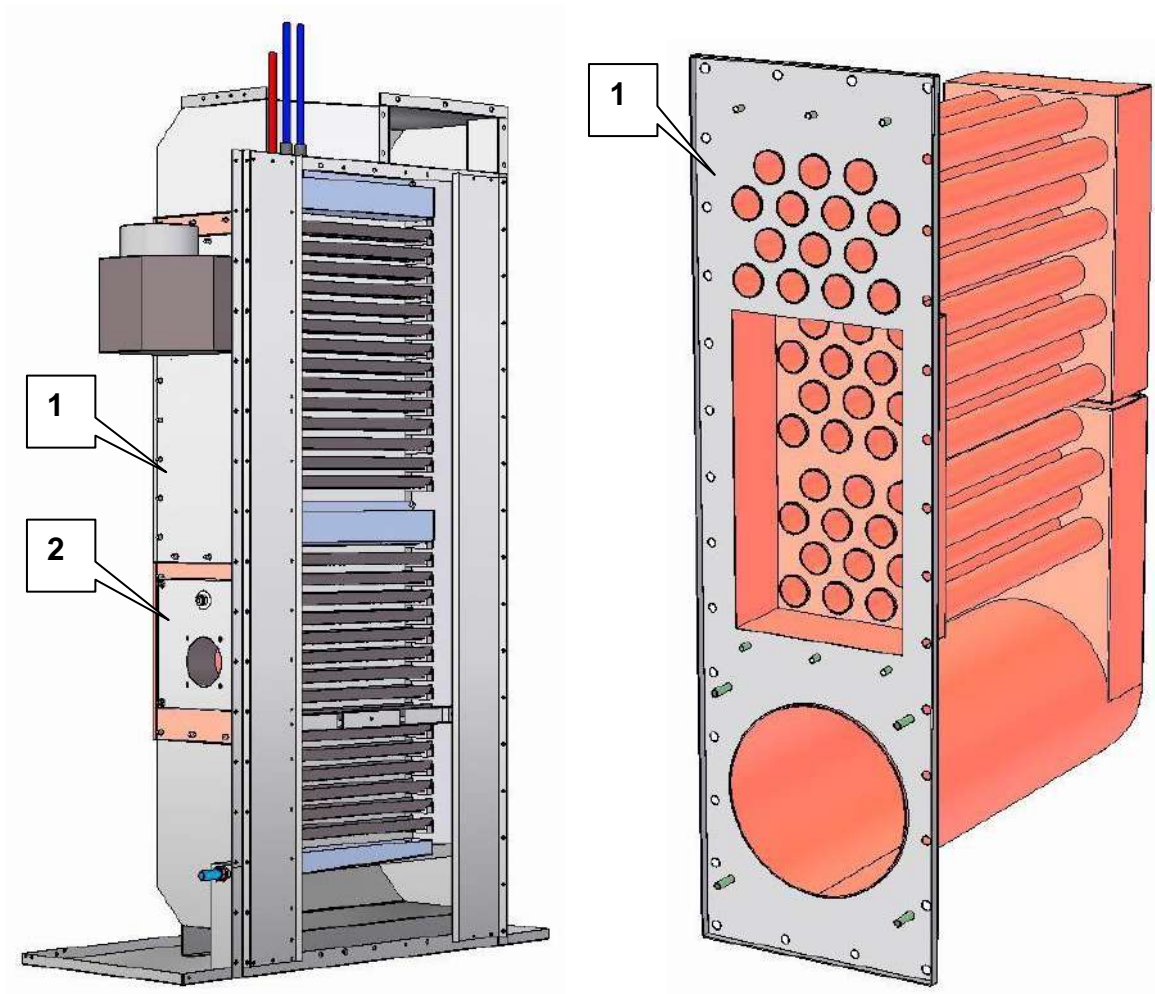

IT Camera di combustione		
Pos.	Codice	Descrizione
1	61001984	CAMERA DI COMBUSTIONE PER J 108
1	61002081	CAMERA DI COMBUSTIONE PER J 128
2	61001986	PORTINA BRUCIATORE PER J 108
2	61002082	PORTINA BRUCIATORE PER J 128

ENG Combustion chamber		
Pos.	Code	Description
1	61001984	COMBUSTION CHAMBER FOR J 108
1	61002081	COMBUSTION CHAMBER FOR J 128
2	61001986	BURNER'S DOOR FOR J 108
2	61002082	BURNER'S DOOR FOR J 128

FR Chambre de combustion		
Pos.	Code	Description
1	61001984	CHAMBRE DE COMBUSTION POUR J 108
1	61002081	CHAMBRE DE COMBUSTION POUR J 128
2	61001986	PORTE DU BRULEUR POUR J 108
2	61002082	PORTE DU BRULEUR POUR J 128

ES Cámara de combustión		
Pos.	Código	Descripción
1	61001984	CAMARA DE COMBUSTION POR J 108
1	61002081	CAMARA DE COMBUSTION POR J 128
2	61001986	PUERTA DEL QUEMADOR POR J 108
2	61002082	PUERTA DEL QUEMADOR POR J 128

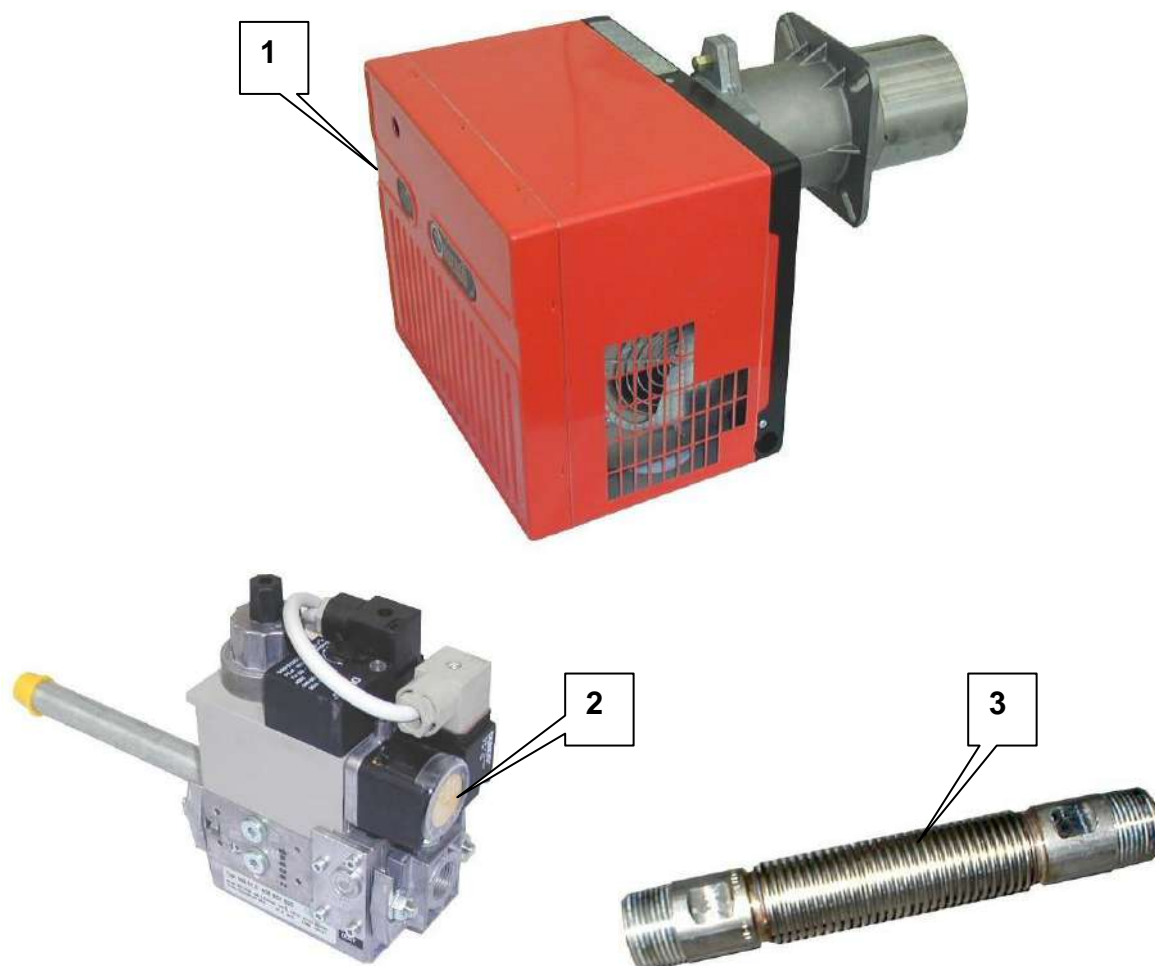

IT Bruciatori		
Pos.	Codice	Descrizione
1	32920005	BRUCIATORE RIELLO 40 F10 (J68)
1	32920022	BRUCIATORE RIELLO 40 FS8 CE 50 HZ (J68)
1	32920005	BRUCIATORE RIELLO 40 F10 (J106/108)
1	32920003	BRUCIATORE RIELLO 40 FS15 CE (J106/108)
	32930017	FILTRO GASOLIO
2	32930040	RAMPA GAS MB 07/1 DIAMETRO 3/4 CE FS15
2	32930064	RAMPA GAS MB DLE 405 B01 (1/2") FS8
3	32930008	GIUNTO ANTIVIBRANTE DA 3/4

ENG Burners		
Pos.	Code	Description
1	32920005	BURNER RIELLO 40 F10 (J68)
1	32920022	BURNER RIELLO 40 FS8 CE 50 HZ (J68)
1	32920005	BURNER RIELLO 40 F10 (J106/108)
1	32920003	BURNER RIELLO 40 FS15 CE (J106/108)
	32930017	GASOIL FILTER
2	32930040	GAS RAMP MB 07/1 DIAMETER 3/4 CE FS15
2	32930064	GAS RAMP MB DLE 405 B01 (1/2") FS8
3	32930008	VIBRATION-DAMPING 3/4-JOINT

FR Brûleurs		
Pos.	Code	Description
1	32920005	BRULEUR RIELLO 40 F10 (J68)
1	32920022	BRULEUR RIELLO 40 FS8 CE 50 HZ (J68)
1	32920005	BRULEUR RIELLO 40 F10 (J106/108)
1	32920003	BRULEUR RIELLO 40 FS15 CE (J106/108)
	32930017	FILTRE GAZOLE
2	32930040	RAMPE GAZE MB 07/1 DIAMETER 3/4 CE FS15
2	32930064	RAMPE GAZE MB DLE 405 B01 (1/2") FS8
3	32930008	¾ JOINT ANTIVIBRANT

ES Quemadores		
Pos.	Código	Descripción
1	32920005	QUEMADOR RIELLO 40 F10 (J68)
1	32920022	QUEMADOR RIELLO 40 FS8 CE 50 HZ (J68)
1	32920005	QUEMADOR RIELLO 40 F10 (J106/108)
1	32920003	QUEMADOR RIELLO 40 FS15 CE (J106/108)
	32930017	FILTRO GASOLEO
2	32930040	RAMPA GAS MB 07/1 DIAMETER 3/4 CE FS15
2	32930064	RAMPA GAS MB DLE 405 B01 (1/2") FS8
3	32930008	JUNTA ¾ ANTIVIBRACION

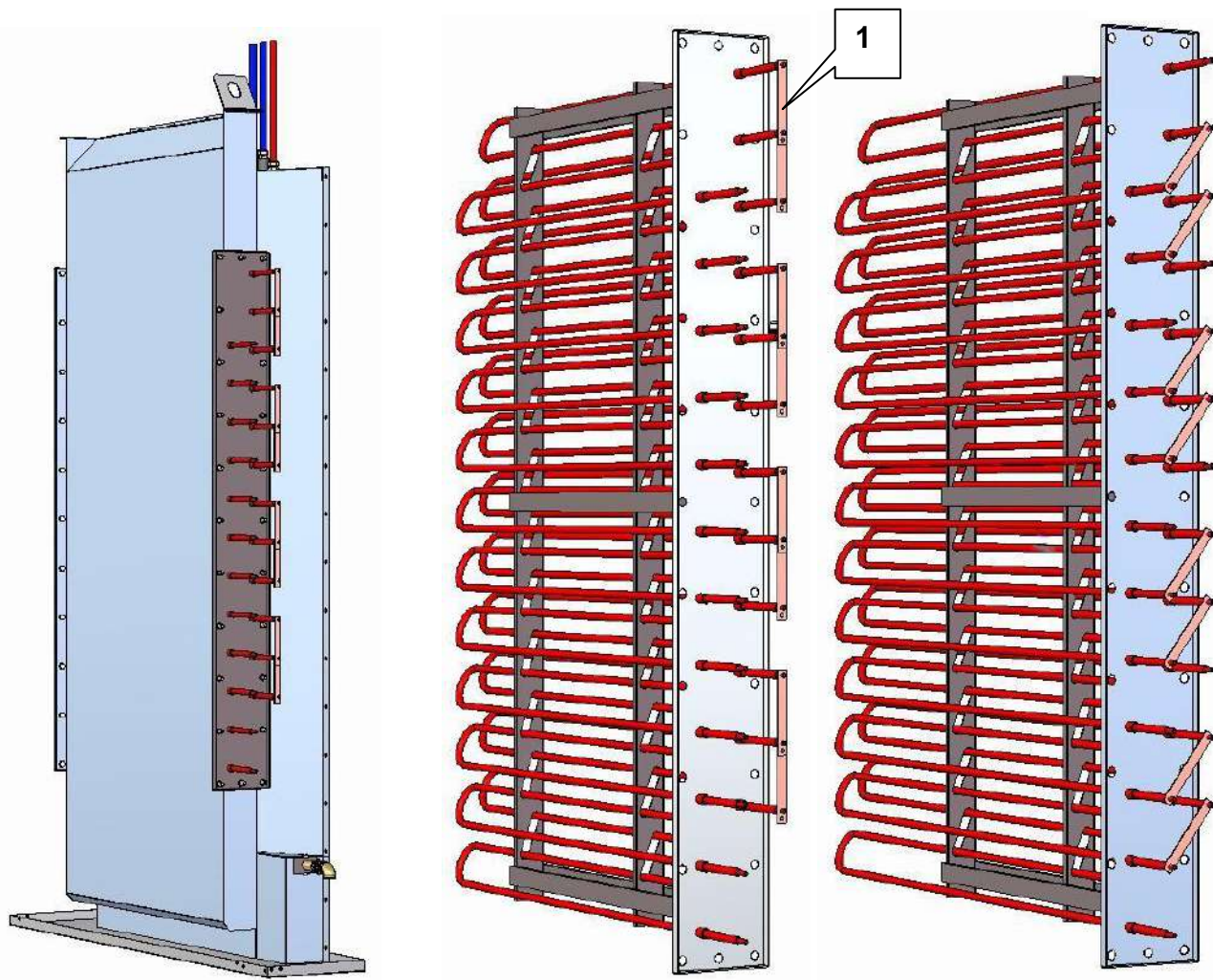

IT Resistenze Elettriche		
Pos.	Codice	Descrizione
	33010056	RESISTENZA PER J68
	33010057	RESISTENZA PER J106/108
1	21007903	PONTI COLLEGAMENTO

ENG Electric resistors		
Pos.	Code	Description
	33010056	HEATING ELEMENT FOR J68
	33010057	HEATING ELEMENT FOR J106/108
1	21007903	CONNECTING BRIDGES

FR Chauffages électriques		
Pos.	Code	Description
	33010056	CHAUFFAGE POUR J68
	33010057	CHAUFFAGE POUR J106/108
1	21007903	PONTS DE CONNEXION

ES Resistencias eléctricas		
Pos.	Código	Descripción
	33010056	RESISTENCIA POR J68
	33010057	RESISTENCIA POR J106/108
1	21007903	PUNTES DE CONNEXION

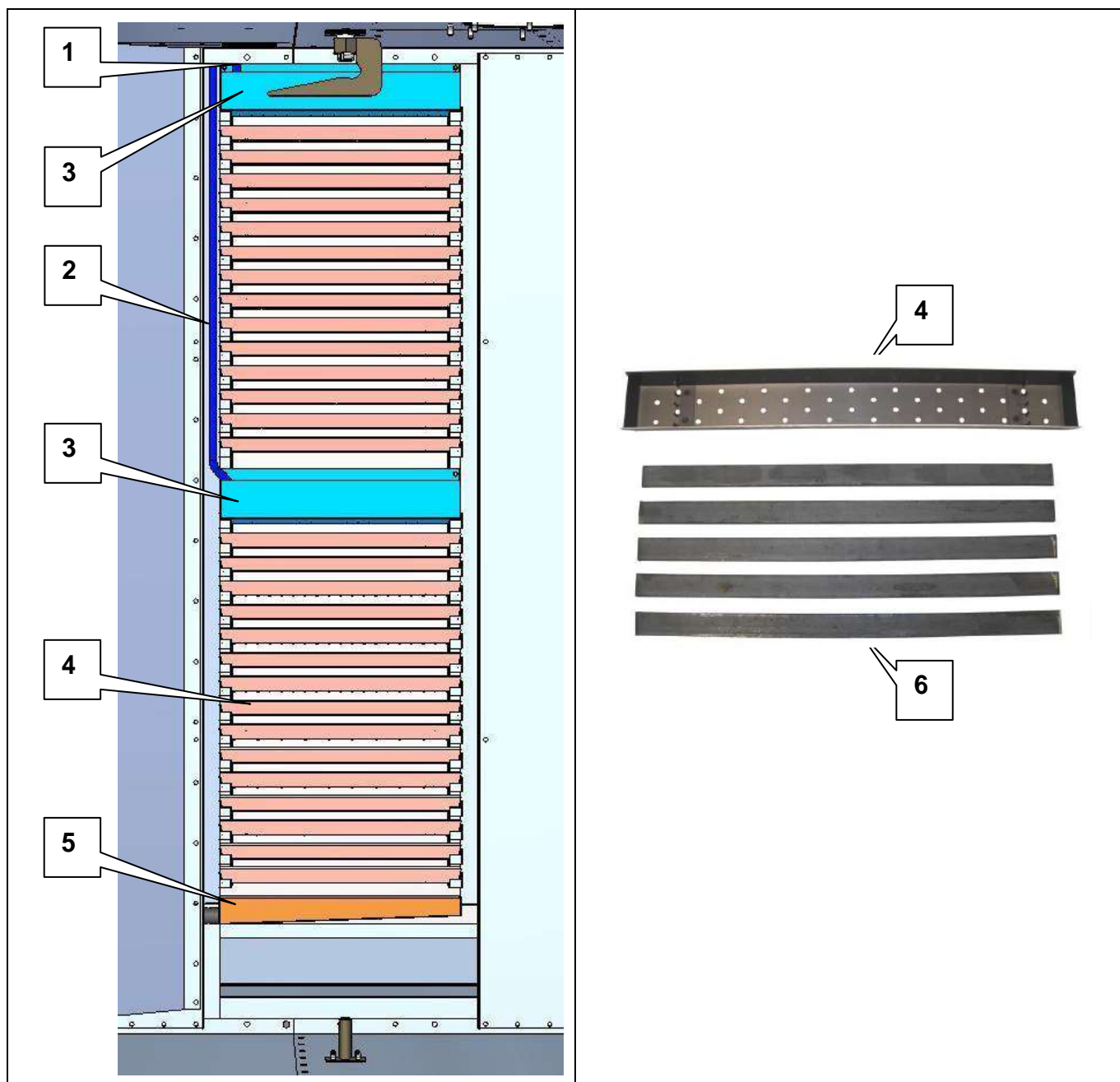

IT Gruppo Vaporiera		
Pos.	Codice	Descrizione
1	26000112	TUBO INGRESSO ACQUA SUPERIORE
2	26000111	TUBO INGRESSO ACQUA MEDIANO
3	21007655	VASCHETTA VAPORIERA A PIATTI SUPERIORE FINITA 68
3	21007982	VASCHETTA VAPORIERA A PIATTI SUPERIORE FINITA 106/108
4	61000777	VASCHETTA VAPORIERA .A PIATTI CENTRALE FINITA 68
4	61000778	VASCHETTA VAPORIERA A PIATTI CENTRALE FINITA 106/108
5	21007654	VASCHETTA VAPORIERA A PIATTI INFERIORE 68
5	21007983	VASCHETTA VAPORIERA A PIATTI INFERIORE 106/108
6	25900068	LAMINATO PIATTO FE360B 25X8X460 68
6	25900069	LAMINATO PIATTO FE360B 25X8X580 106/108

ENG Steam generator's group		
Pos.	Code	Description
1	26000112	UPPER INLET WATER PIPE
2	26000111	MIDDLE INLET WATER PIPE
3	21007655	STEAM GENERATOR'S UPPER FINISHED FLAT TRAY 68
3	21007982	STEAM GENERATOR'S UPPER FINISHED FLAT TRAY 106/108
4	61000777	STEAM GENERATOR'S CENTRAL FINISHED FLAT TRAY 68
4	61000778	STEAM GENERATOR'S CENTRAL FINISHED FLAT TRAY 106/108
5	21007654	STEAM GENERATOR'S LOWER FINISHED FLAT TRAY 68
5	21007983	STEAM GENERATOR'S LOWER FINISHED FLAT TRAY 106/108
6	25900068	FLAT LAMINATE FE360B 25X8X460 68
6	25900069	FLAT LAMINATE FE360B 25X8X580 106/108

FR Groupe générateur de vapeur		
Pos.	Code	Description
1	26000112	TUYAU EAU ENTRÉE SUPERIEURE
2	26000111	TUYAU EAU ENTREE MEDIANE
3	21007655	PLATEAU SUPERIEUR FINI DU GENERATEUR VAPEUR 68
3	21007982	PLATEAU SUPERIEUR FINI DU GENERATEUR VAPEUR 106/108
4	61000777	PLATEAU MEDIAN FINI DU GENERATEUR VAPEUR 68
4	61000778	PLATEAU MEDIAN FINI DU GENERATEUR VAPEUR 106/108
5	21007654	PLATEAU INFERIEUR FINI DU GENERATEUR VAPEUR 68
5	21007983	PLATEAU INFERIEUR FINI DU GENERATEUR VAPEUR 106/108
6	25900068	LAMIFIE PLAT FE360B 25X8X460 68
6	25900069	LAMIFIE PLAT FE360B 25X8X580 106/108

ES Grupo generador de vapor		
Pos.	Código	Descripción
1	26000112	TUBO AGUA ENTRADA SUPERIOR
2	26000111	TUBO AGUA ENTRADA MEDIA
3	21007655	BANDEJA SUPERIOR COMPLETA DEL GENERADOR VAPOR 68
3	21007982	BANDEJA SUPERIOR COMPLETA DEL GENERADOR VAPOR 106/108
4	61000777	BANDEJA MEDIA COMPLETA DEL GENERADOR VAPOR 68
4	61000778	BANDEJA MEDIA COMPLETA DEL GENERADOR VAPOR 106/108
5	21007654	BANDEJA INFERIOR COMPLETA DEL GENERADOR VAPOR 68
5	21007983	BANDEJA INFERIOR COMPLETA DEL GENERADOR VAPOR 106/108
6	25900068	LAMINADO PLANO FE360B 25X8X460 68
6	25900069	LAMINADO PLANO FE360B 25X8X580 106/108

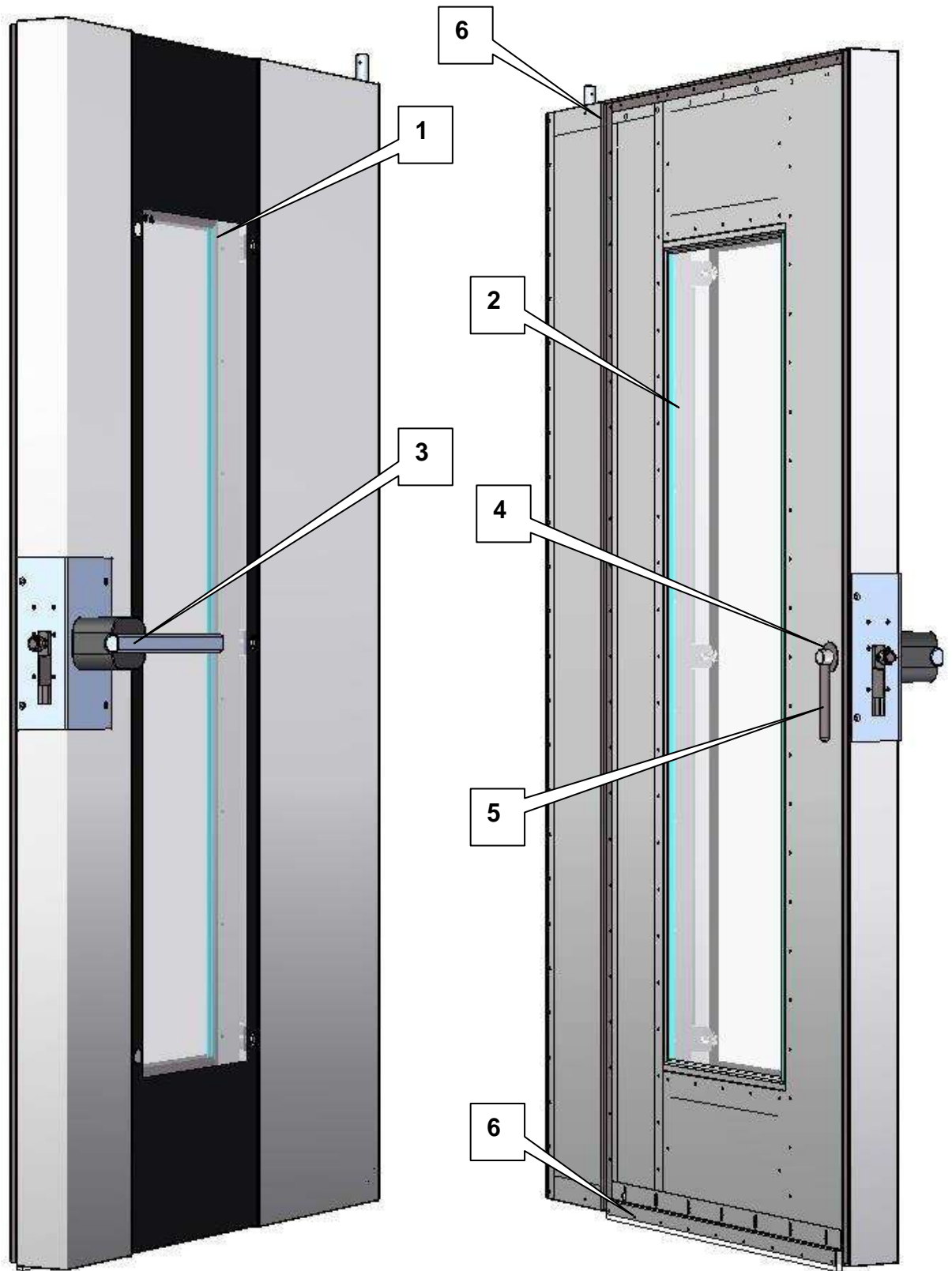

IT Porta della Camera di Cottura

1. Vetro esterno apribile a compasso : Cod. 41000111
2. Vetro interno in guarnizione : Cod. 41000084
3. Gruppo maniglia (Pagina seguente)
4. Guarnizione di tenuta in silicone : Cod. 43900034
5. Maniglia interna di sicurezza (Pagina seguente)
6. Guarnizione porta (al Metro) : Cod. 43000027

ENG Baking chamber's door

1. External glass, with rear drop side: Code 41000111
2. Inside glass, with gasket: Code 41000084
3. Handle group (following page)
4. Silicone sealing gasket: Code 43900034
5. Inside safety handle (following page)
6. Door gasket (at Meter): Code 43000027

FR Porte de la chambre de cuisson

1. Vitre extérieur, ouvrable en compas: Code 41000111
2. Vitre intérieur, avec joint: Code 41000084
3. Groupe poignée (page suivante)
4. Garniture de collage en silicone: Code 43900034
5. Poignée intérieure de sécurité (page suivante)
6. Garniture porte (mètre): Code 43000027

ES Puerta de la cámara de cocción

1. Vidrio exterior, apribile a compás: Código 41000111
1. Vidrio interior, con junta: Código 41000084
2. Grupo manilla (página siguiente)
3. Junta de sello en silicona: Código 43900034
4. Manilla interior de seguridad (página siguiente)
5. Junta puerta (Metro): Código 43000027

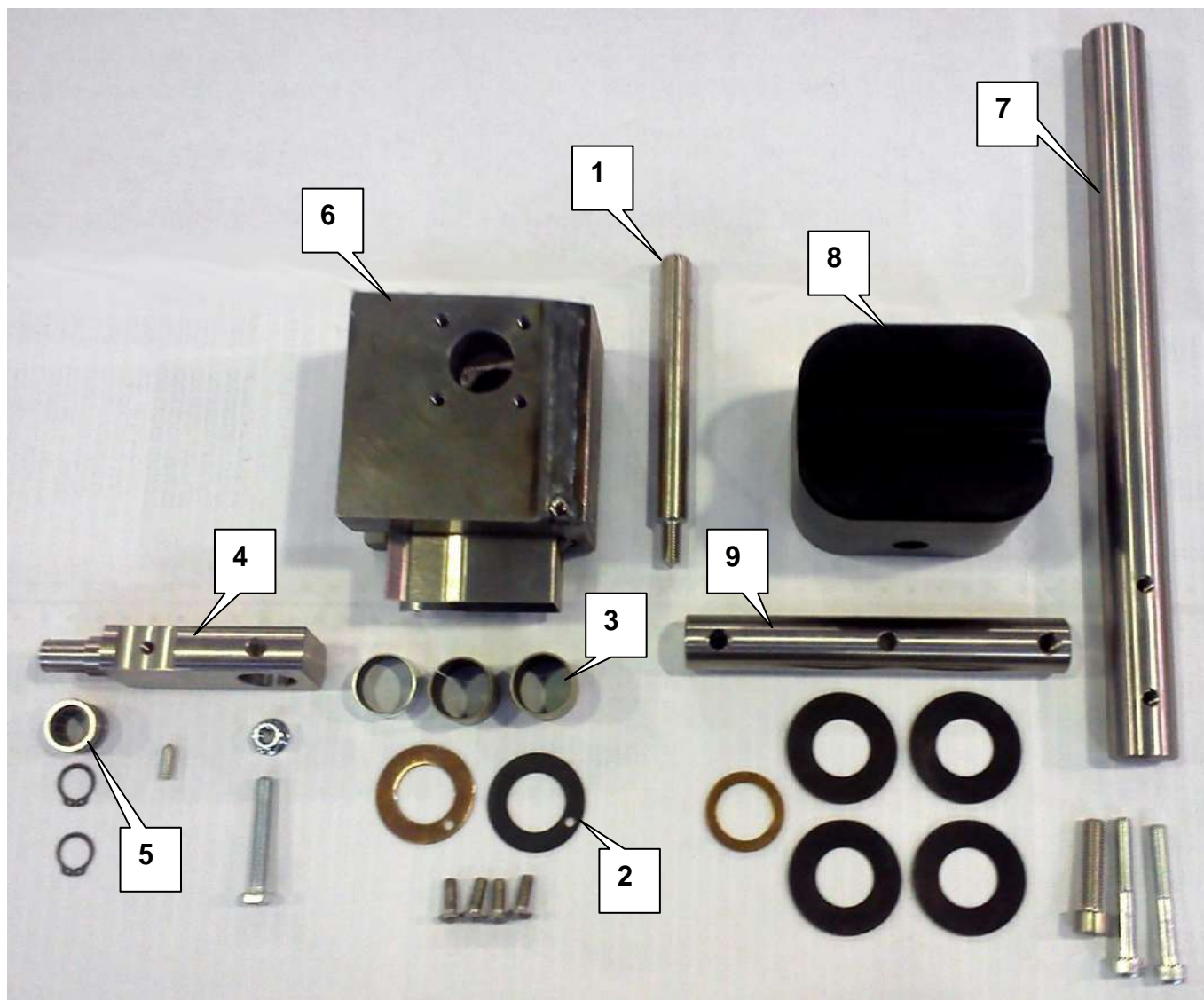

IT Gruppo maniglia porta		
Pos.	Codice	Descrizione
1	26000070	MANIGLIA INTERNA DIAMETRO 15X167
2	57900005	RALLA AUTOLUBRIFICANTE TFW 26/1 (26/44/1,5)
3	57900004	BOCCOLA AUTOLUBRIFICANTE TFP (25/28/15)
4	26000013	SCROCCO PORTA LUNGHEZZA 120
5	57900002	CUSCINETTO A RULLI (15X23X16)
6	25000094	SCATOLA MANIGLIA PORTA FINITA
7	26000118	MANIGLIA ESTERNA
8	25000673	BASE MANIGLIA ESTERNA
9	26000101	ALBERO MANIGLIA ESTERNA

ENG Door handle's group		
Pos.	Code	Description
1	26000070	INSIDE HANDLE DIAMETER 15X167
2	57900005	SELF-LUBRICATING FIFTH WHEEL TFW 26/1 (26/44/1,5)
3	57900004	SELF-LUBRICATING BUSHING TFP (25/28/15)
4	26000013	DOOR LATCH, LENGTH 120
5	57900002	ROLLER BEARING (15X23X16)
6	25000094	DOOR HANDLE'S BOX FINISHED
7	26000118	EXTERNAL HANDLE

8	25000673	EXTERNAL HANDLE'S BASE
9	26000101	EXTERNAL HANDLE'S SHAFT

FR Groupe poignée porte		
Pos.	Code	Description
1	26000070	POIGNEE INTERIEURE DIAMETRE 15X167
2	57900005	SELLETTE AUTOLUBRIFIANTE TFW 26/1 (26/44/1,5)
3	57900004	DOUILLE AUTOLUBRIFIANTE TFP (25/28/15)
4	26000013	VERROU DE PORTE, LONGUEUR 120
5	57900002	PALIER A ROULEAUX (15X23X16)
6	25000094	BOITE DE LA POIGNEE PORTE FINIE
7	26000118	POIGNEE EXTERIEURE
8	25000673	BASE DE LA POIGNEE EXTERIEURE
9	26000101	ARBRE DE LA POIGNEE EXTERIEURE

ES Grupo manilla de la puerta		
Pos.	Código	Descripción
1	26000070	MANILLA INTERIOR DIAMETRO 15X167
2	57900005	QUINTA RUEDA AUTO-LUBRICANTE TFW 26/1 (26/44/1,5)
3	57900004	BUJE AUTO-LUBRICANTE TFP (25/28/15)
4	26000013	CIERRE DE PUERTA, LARGURA 120
5	57900002	RODAMIENTO DE RODILLOS (15X23X16)
6	25000094	CAJA TERMINADA DE LA MANILLA PUERTA
7	26000118	MANILLA EXTERIOR
8	25000673	BASE DE LA MANILLA EXTERIOR
9	26000101	EJE DE LA MANILLA EXTERIOR

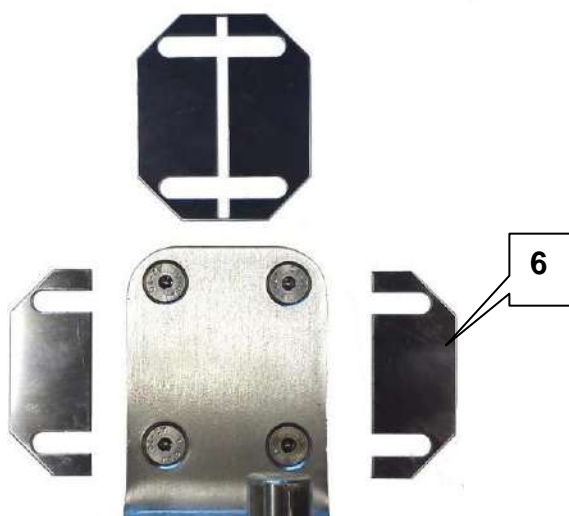
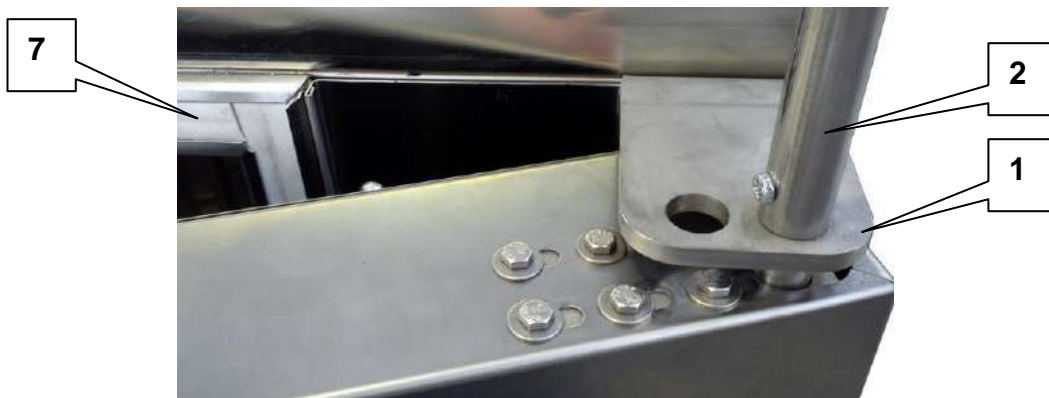

IT Cerniere della Porta		
Pos.	Codice	Descrizione
1	21000404	CERNIERA SUPERIORE
2	26000024	TUBO PER CAMMA FINECORSIA PORTA
	23000118	CAMMA PER FINECORSIA
3	26000016	CERNIERA INFERIORE
4	53901004	RONDELLA OTTONE
5	21000838	RONDELLE INOX
6	21000452	SPESSORI PER LE CERNIERE
7	43000027	GUARNIZIONE LATERALE E SUPERIORE (AL MT)

ENG Door's hinges		
Pos.	Code	Description
1	21000404	UPPER HINGE
2	26000024	TUBE FOR DOOR'S CAM LIMIT SWITCH
	23000118	CAM FOR LIMIT SWITCH
3	26000016	LOWER HINGE
4	53901004	BRASS WASHER
5	21000838	STAINLESS WASHER
6	21000452	HINGES' THICKNESSES
7	43000027	LATERAL AND UPPER GASKETS (AT METER)

FR Charnières porte		
Pos.	Code	Description
1	21000404	CHARNIERE SUPERIEURE
2	26000024	TUYEAU POUR CAME FIN DE COURSE DE LA PORTE
	23000118	CAME POUR FIN DE COURSE
3	26000016	CHARNIERE INFERIEURE
4	53901004	RONDELLE EN LAITON
5	21000838	RONDELLE EN ACIER INOXYDABLE
6	21000452	EPAISSEURS DES CHARNIERES
7	43000027	JOINTS LATERAUX ET SUPERIEURS (AU METRE)

ES Bisagras de puerta		
Pos.	Código	Description
1	21000404	BISAGRA SUPERIOR
2	26000024	TUBO POR LEVA DEL FINAL DE CARRERA DE LA PUERTA
	23000118	LEVA POR EL FINAL DE CARRERA
3	26000016	BISAGRA INFERIOR
4	53901004	ARANDELA EN LATON
5	21000838	ARANDELA EN ACERO INOXIDABLE
6	21000452	GROSORES DE LAS BISAGRAS
7	43000027	JUNTAS LATERALES Y SUPERIORES (AL METRO)

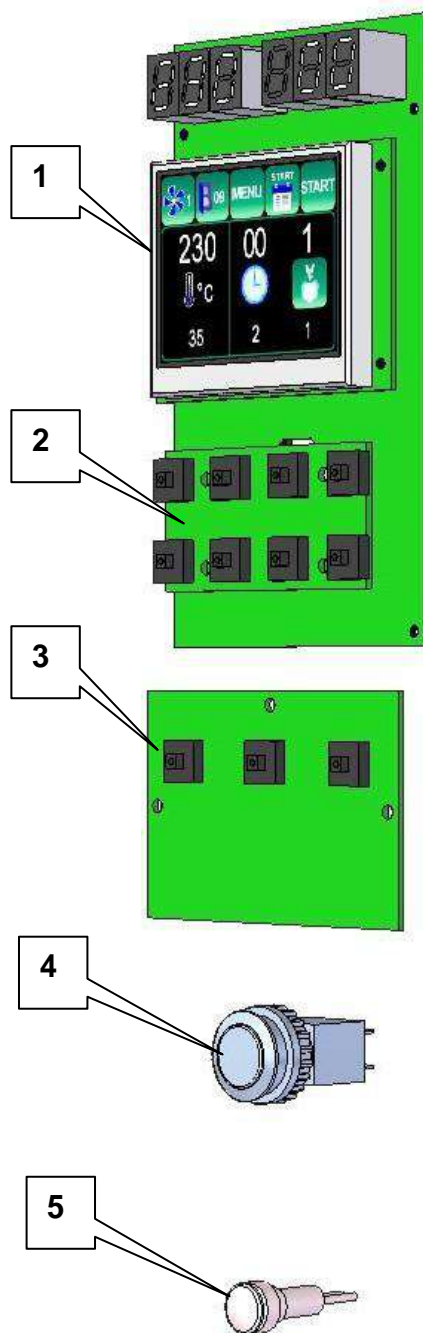

IT Pannello comandi digitale per versioni a combustione		
Pos.	Codice	Descrizione
1	39080182	SCHEDA CON LCD A COLORI
2	39080089	TASTIERA DELLA SCHEDA
3	39080184	SCHEDA A 3 TASTI
4	39910020	INTERRUTTORE GENERALE
5	39950042	SIGNALUX BIANCA 230V

ENG Digital control panel for combustion versions		
Pos.	Code	Description
1	39080182	COLOR LCD'S BOARD
2	39080089	KEYBOARD
3	39080184	THREE-BUTTON BOARD
4	39910020	GENERAL SWITCH
5	39950042	SIGNALUX WHITE 230V

FR Tableau de bord digital pour versions à combustion		
Pos.	Code	Description
1	39080182	TABLEAU LCD EN COULEUR
2	39080089	CLAVIER
3	39080184	TABLEAU A 3 BOUTONS
4	39910020	INTERRUPTEUR GENERAL
5	39950042	SIGNALUX BLANC 230V

ES Panel de mando digital por versiones a combustion		
Pos.	Código	Descripción
1	39080182	TABLERO LCD A COLORES
2	39080089	TECLADO
3	39080184	TABLERO A 3 BOTONES
4	39910020	INTERRUPTOR GENERAL
5	39950042	SIGNALUX BLANCO 230V

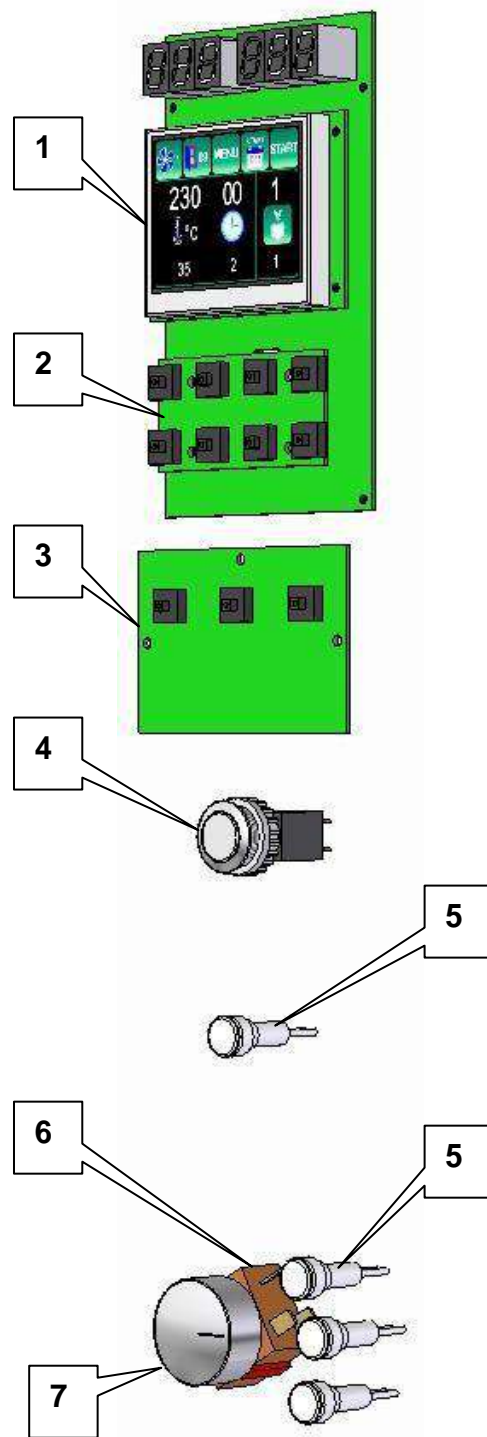
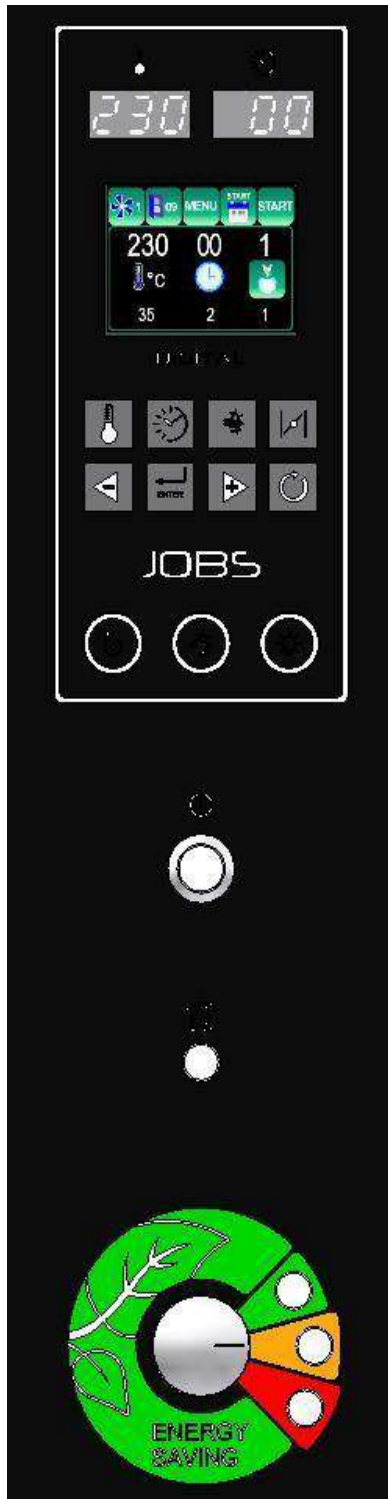

IT Pannello comandi digitale per versioni elettriche		
Pos.	Codice	Descrizione
1	39080182	SCHEDA CON LCD A COLORI
2	39080089	TASTIERA DELLA SCHEDA
3	39080184	SCHEDA A 3 TASTI
4	39910020	INTERRUTTORE GENERALE
5	39950042	SIGNALUX BIANCA 230V
6	39960093	SELETTORE ROTATIVO
7	39960086	MANOPOLA DEL SELETTORE

ENG Digital control panel for electric versions		
Pos.	Code	Description
1	39080182	COLOR LCD'S BOARD
2	39080089	KEYBOARD
3	39080184	THREE-BUTTON BOARD
4	39910020	GENERAL SWITCH
5	39950042	SIGNALUX WHITE 230V
6	39960093	ROTARY SWITCH
7	39960086	SWITCH'S HANDLE

FR Tableau de bord digital pour versions électriques		
Pos.	Code	Description
1	39080182	TABLEAU LCD EN COULEUR
2	39080089	CLAVIER
3	39080184	TABLEAU A 3 BOUTONS
4	39910020	INTERRUPTEUR GENERAL
5	39950042	SIGNALUX BLANC 230V
6	39960093	COMMUTATEUR ROTATIF
7	39960086	POIGNEE DU COMMUTATEUR

ES Panel de mando digital por versiones eléctricas		
Pos.	Código	Descripción
1	39080182	TABLERO LCD A COLORES
2	39080089	TECLADO
3	39080184	TABLERO A 3 BOTONES
4	39910020	INTERRUPTOR GENERAL
5	39950042	SIGNALUX BLANCO 230V
6	39960093	INTERRUPTOR GIRATORIO
7	39960086	MANILLA DEL INTERRUPTOR

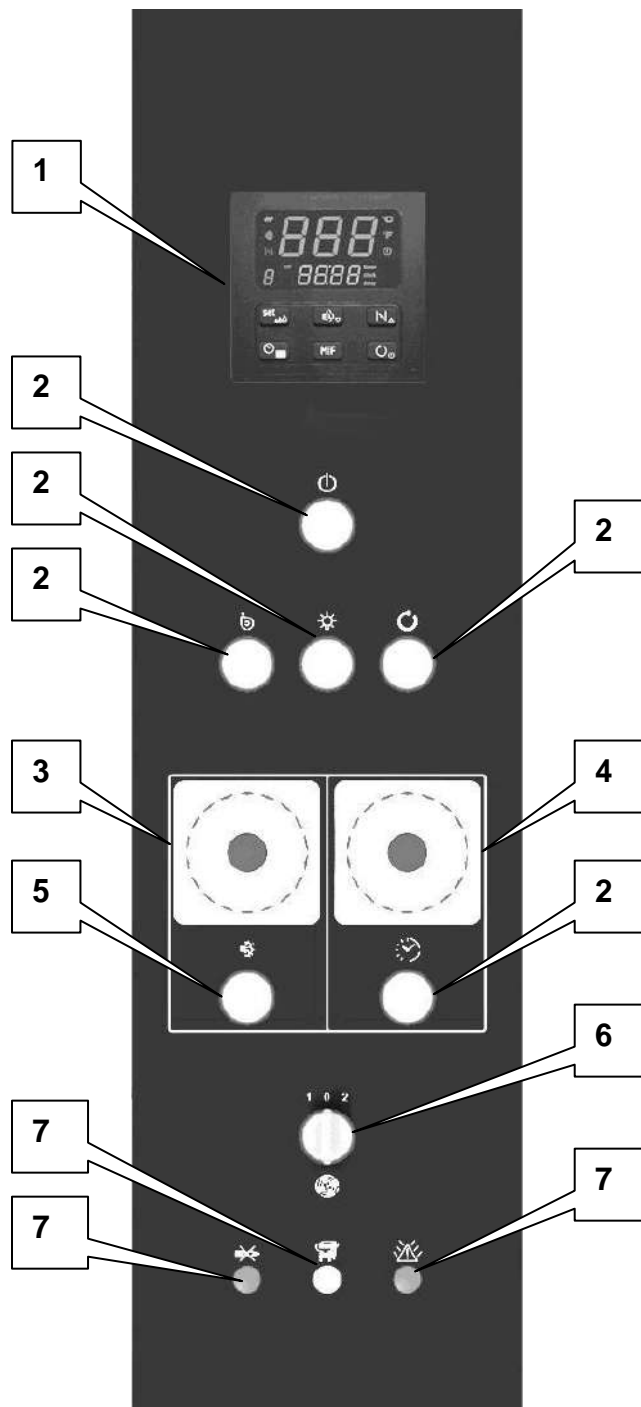

IT Pannello Comandi Elettromeccanico		
Pos.	Codice	Descrizione
1	35000030	TERMOREGOLATORE
2	39910005	INTERRUTTORE LUMINOSO BIANCO
3	39930005	TIMER CDC IN SECONDI
4	39930005	TIMER CDC IN MINUTI (X 10)
5	39960090	PULSANTE BIANCO
6	39910004	SELETTORE LUMINOSO (1 O 2)
7	39950042	SIGNALUX BIANCA 230V

ENG Electromechanical control panel		
Pos.	Code	Description
1	35000011	THERMOREGULATOR
2	39910005	WHITE LIGHT SWITCH
3	39930005	TIMER CDC IN SECONDS
4	39930005	TIMER CDC IN MINUTES (X 10)
5	39960090	WHITE BUTTON
6	39910004	LIGHT SELECTOR (1 OR 2)
7	39950042	SIGNALUX WHITE 230V

FR Tableau de bord électromécanique		
Pos.	Code	Description
1	35000011	THERMOREGULATEUR
2	39910005	INTERRUPTEUR LUMINEUX BLANC
3	39930005	TEMPORISATEUR CDC EN SECONDS
4	39930005	TEMPORISATEUR CDC EN MINUTES (X 10)
5	39960090	BOUTON BLANC
6	39910004	SELECTEUR LUMINEUX (1 OU 2)
7	39950042	SIGNALUX BLANC 230V

ES Panel de mando electromecánico		
Pos.	Código	Descripción
1	35000011	TERMOREGULADOR
2	39910005	INTERRUPTOR DE LUZ BLANCO
3	39930005	TEMPORIZADOR CDC EN SEGUNDOS
4	39930005	TEMPORIZADOR CDC EN MINUTOS (X 10)
5	39960090	BOTON BLANCO
6	39910004	SELECTOR DE LUZ (1 O 2)
7	39950042	SIGNALUX BLANCO 230V

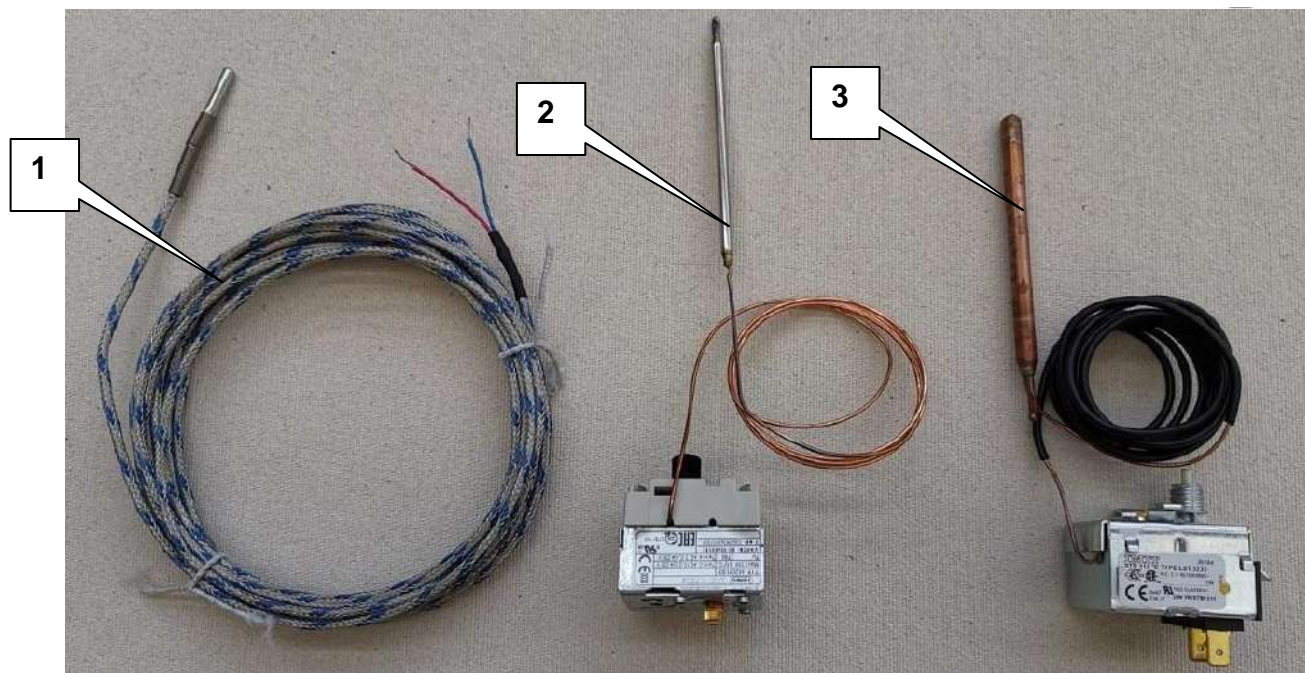

IT Termocoppia e Termostati di Sicurezza		
Pos.	Codice	Descrizione
1	39970063	TERMOCOPPIA J DIAM. 8X100, CAVO SCHERMATO 5MT
2	39930024	TERMOSTATO R/M 350°C
3	39930007	TERMOSTATO R.M. 90/110°C, L 1500 (SOLO PER VERSIONI A COMBUSTIBILE)

ENG Thermocouple and safety thermostats		
Pos.	Code	Description
1	39970063	THERMOCOUPLE J DIAM. 8X100, SCREENED CABLE 5MT
2	39930024	THERMOSTAT R/M 350°C
3	39930007	THERMOSTAT R.M. 90/110°C, L 1500 (ONLY FOR COMBUSTION VERSIONS)

FR Thermocouple et thermostats de sécurité		
Pos.	Code	Description
1	39970063	THERMOCOUPLE J DIAM. 8X100, CABLE BLINDE 5MT
2	39930024	THERMOSTAT R/M 350°C
3	39930007	THERMOSTAT R.M. 90/110°C, L 1500 (SEULEMENT POUR VERSIONS COMBUSTION)

ES Termopar y termostatos de seguridad		
Pos.	Código	Descripción
1	39970063	TERMOPAR J DIAM. 8X100, CABLE BLINDADO 5MT
2	39930024	TERMOSTATO R/M 350°C
3	39930007	TERMOSTATO R.M. 90/110°C, L 1500 (SOLO POR VERSIONES A COMBUSTION)



IT Finecorsa		
Pos.	Codice	Descrizione
1	39970031	FINECORSA PORTA
2	39970032	FINECORSA CARRELLO

ENG Limit switch		
Pos.	Code	Description
1	39970031	DOOR'S LIMIT SWITCH
2	39970032	RACK'S LIMIT SWITCH

FR Fin de course		
Pos.	Code	Description
1	39970031	FIN DE COURSE DE LA PORTE
2	39970032	FIN DE COURSE DU CHARIOT

ES Final de carrera		
Pos.	Código	Descripción
1	39970031	FINAL DE CARRERA DE LA PUERTA
2	39970032	FINAL DE CARRERA DEL CARRO

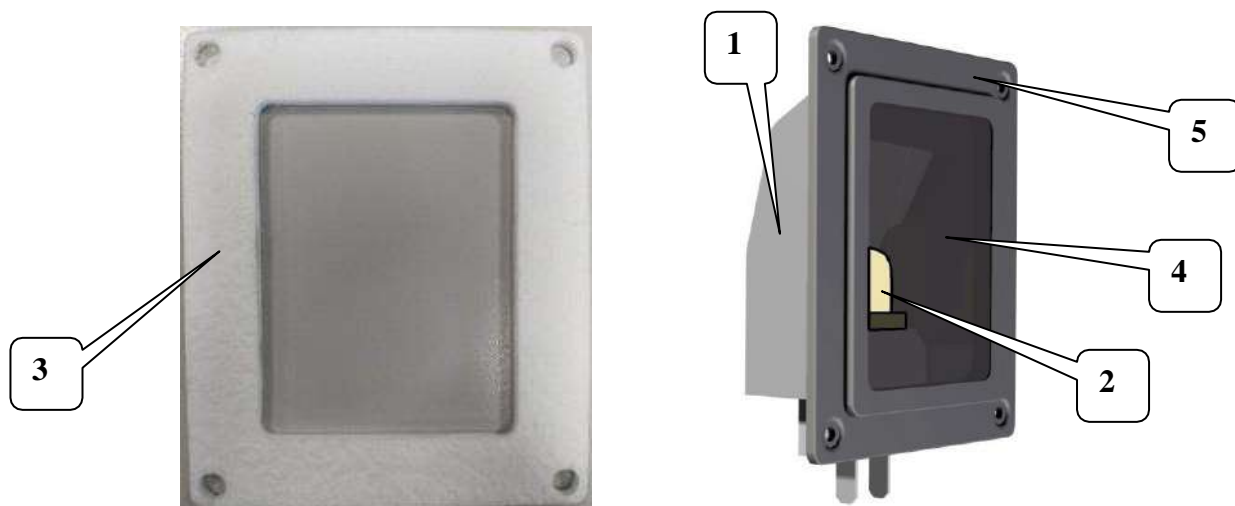

NUM	COD.	DESCRIZIONE
1	39950039	PORTALAMPADA PER LAMPADINA ALOGENA G9 (<10/2015)
2	39950038	LAMPADINA ALOGENA G9 , 40W , 230V (<10/2015)
1	39950044	PORTALAMPADA PER LAMPADINE ATTACCO E14 (>11/2015)
2	39950046	LAMPADINA INCANDESCENZA 25W 230V ATTACCO E14 (>11/2015)
3	43000023	GUARNIZIONE 92X77X3 CARTA CERAMICA
4	41000080	VETRO PORTALAMPADA
5	54900239	CORNICE METALLICA PER PORTALAMPADA

NUM	COD.	DESCRIPTION
1	39950039	LAMP HOLDER FOR HALOGENE LAMP (<10/2015)
2	39950038	HALOGEN LAMP G9 , 40W , 230V (<10/2015)
1	39950044	LAMP HOLDER FOR INCANDESCENT LAMP (>11/2015)
2	39950046	INCANDESCENT LAMP 25W 230V ATTACHMENT E14 (>11/2015)
3	43000023	GASKET 92X77X3 CERAMIC PAPER
4	41000080	GLASS FOR LAMPHOLDER
5	54900239	METAL FRAME FOR LAMP HOLDER

NOM	COD.	DESCRIPTION
1	39950039	PORT-AMPOULE POUR AMPOULE HALOGENE (<10/2015)
2	39950038	AMPOULE HALOGENE G9 , 40W , 230V (<10/2015)
1	39950044	PORT-AMPOULE POUR AMPOULE A INCANDESCENCE E14 (>11/2015)
2	39950046	AMPOULE A INCANDESCENCE 25W 230V ATTACHE E14 (>11/2015)
3	43000023	DOUILLE 92X77X3 PAPIER CÉRAMIQUE
4	41000080	VERRE POUR PORTE-AMPOULE
5	54900239	CADRE METALLIQUE POUR PORT-AMPOULE

NUM	COD.	DESCRIPCION
1	39950039	PORTALÁMPARAS PARA LÁMPARA HALÓGENA (<10/2015)
2	39950038	LÁMPARA HALÓGENA G9 , 40W , 230V (<10/2015)
1	39950044	PORTALAMPARAS PARA BOMBILLA MONTAJE E14 (>11/2015)
2	39950046	BOMBILLA INCANDESCENTE 25W 230V MONTAGE E14 (>11/2015)
3	43000023	GUARNICIÓN 92X77X3 PAPEL CERAMICO
4	41000080	VIDRO PARA PORTALÁMPARAS
5	54900239	MARCO DE METAL PARA EL PORTALÁMPARAS

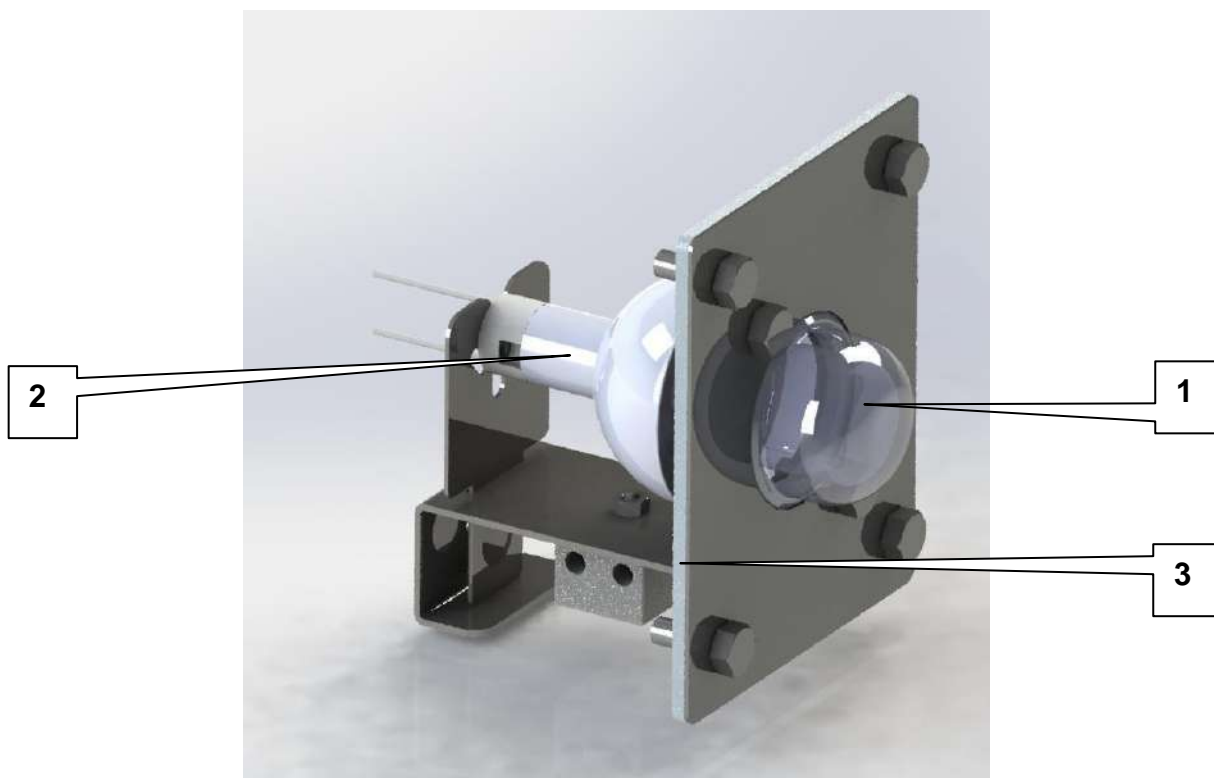

IT Portalampade		
Pos.	Codice	Descrizione
1	41000018	VETRO
2	39950049	LAMPADA ALOGENA GU10 35W 230V (DAL 11/2017 AL 06/2018)
3	43000038	GUARNIZIONE
	61002678	GRUPPO COMPLETO
ENG Lamp holders		
Pos.	Code	Description
1	41000018	GLASS
2	39950049	HALOGEN BULB GU10 35W 230V (FROM 11/2017 TO 06/2018)
3	43000038	SEAL
	61002678	COMPLETE GROUP

FR Porte-lampes		
Pos.	Code	Description
1	41000018	VERRE
2	39950049	HALOGÈNE BULBE GU10 35W 230V (À PARTIR DE 11/2017 JUSQU'AU 06/2018)
3	43000038	JOINT
	61002678	GROUPE COMPLET

ES Portalámparas		
Pos.	Código	Descripción
1	41000018	VIDRIO
2	39950049	LAMPARA HALÓGENA GU10 35W 230V (DESDE 11/2017 HASTA 06/2018)
3	43000038	SELLO
	61002678	GRUPO COMPLETO

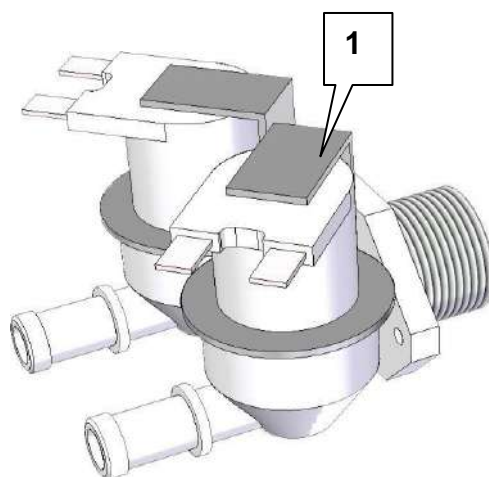

IT Electrovalvola e Gruppo Acqua		
Pos.	Codice	Descrizione
1	55900153	DOPPIA ELETTROVALVOLA 3/4" MINI 230 V
	55900150	TUBO GOMMA EDPM 10X20 GIALLO, MT 2
	54900009	FASCETTA STRINGI TUBO
	55900159	RACCORDO PORTAGOMMA 1/2", DIAMETRO 10
	55900124	TUBO NYLONFLEX DN10 F3/4GI-CF3/4GI MM 500
	55900068	RACCORDO MASCHIO 1/2" X14 CON OGIVA

ENG Electrovalve and water group		
Pos.	Code	Description
1	55900153	DOUBLE ELECTROVALVE 3/4" MINI 230 V
	55900150	RUBBER PIPE EDPM 10X20 YELLOW, MT 2
	54900009	PIPE CLAMP
	55900159	HOSE CONNECTION 1/2" DIAM.10
	55900124	NYLONFLEX PIPE DN10 F3/4GI-CF3/4GI MM 500
	55900068	MALE CONNECTION 1/2"X14 WITH OGIVE

FR Electrovanne et groupe eau		
Pos.	Code	Description
1	55900153	DOUBLE ELECTROVANNE 3/4" MINI 230 V
	55900150	TUYAU EN GOMME EDPM 10X20 YELLOW, MT 2
	54900009	COLLIER POUR TUYAU
	55900159	RACCORD DE TUYAU 1/2" DIAM.10
	55900124	TUYAU NYLONFLEX DN10 F3/4GI-CF3/4GI MM 500
	55900068	CONNEXION MALE 1/2"X14 AVEC OGIVE

ES Electroválvula y grupo agua		
Pos.	Código	Descripción
1	55900153	DOBLE ELECTROVALVULA 3/4" MINI 230 V
	55900150	TUBO DE GOMA EDPM 10X20 AMARILLO, MT 2
	54900009	ABRAZADERA DE TUBO
	55900159	CONEXION PARA MANGUERAS 1/2" DIAM.10
	55900124	TUBO NYLONFLEX DN10 F3/4GI-CF3/4GI MM 500
	55900068	CONEXION MACHO 1/2"X14 CON OJIVA

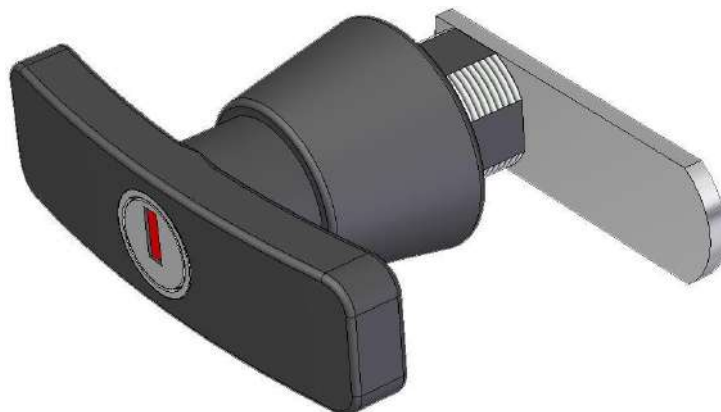

IT Maniglia Porta Comandi		
Pos.	Codice	Descrizione
	54900266	MANIGLIA PORTA COMANDI

ENG Control door's handle		
Pos.	Codice	Description
	54900266	CONTROL DOOR'S HANDLE

FR Poignée porte de commande		
Pos.	Codice	Description
	54900266	POIGNEE DE LA PORTE DE COMMANDE

ES Manilla puerta de control		
Pos.	Código	Descripción
	54900266	MANILLA DE LA PUERTA DE CONTROL

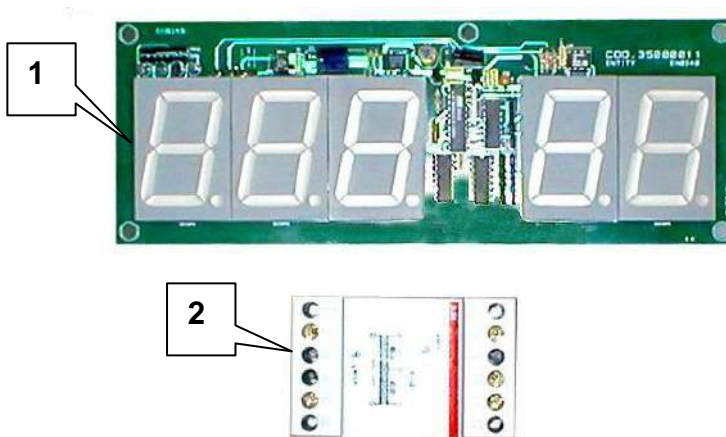

IT Visualizzatore Cappa		
Pos.	Codice	Descrizione
1	35000024	SCHEDA DISPLAY CAPP A C/RS 385
2	39940008	TRASFORMATORE MONOFASE 30V A 230V 0-24V

ENG Hood's display		
Pos.	Code	Description
1	35000024	BOARD OF HOOD'S DISPLAY C/RS 385
2	39940008	SINGLE-PHASE TRANSFORMER 30V A 230V 0-24V

FR Écran hotte		
Pos.	Code	Description
1	35000024	PANNEAU DE L'ECRAN DE LA HOTTE C/RS 385
2	39940008	TRANSFORMATEUR MONOPHASE 30V A 230V 0-24V

ES Pantalla de la campana		
Pos.	Código	Descripción
1	35000024	PANEL DE LA PANTALLA DE LA CAMPANA C/RS 385
2	39940008	TRANSFORMADOR MONOFASICO 30V A 230V 0-24V



IT Isolamento		
Pos.	Codice	Descrizione
1	43900002	MATERASSINO TIPO FELTRO 10 KG
2	43900116	PANNELLO ALTA TEMPERATURA 1000X600X40 DENSITA' 80
2	43900117	PANNELLO ALTA TEMPERATURA 1000X600X30 DENSITA' 80

ENG Isolation		
Pos.	Code	Description
1	43900002	MATTRESS FELT TYPE 10 KG
2	43900116	HIGH TEMPERATURE PANEL 1000X600X40 DENSITY 80
2	43900117	HIGH TEMPERATURE PANEL 1000X600X30 DENSITY 80

FR Insulation		
Pos.	Code	Description
1	43900002	MATELAS TYPE FEUTRE 10 KG
2	43900116	HAUTE TEMPERATURE PANEL 1000X600X40 DENSITÉ 80
2	43900117	HAUTE TEMPERATURE PANEL 1000X600X30 DENSITÉ 80

ES Aislamiento		
Pos.	Código	Descripción
1	43900002	COLCHON TIPO FIELTRO 10 KG
2	43900116	PANEL ALTA TEMPERATURA 1000X600X40 DENSIDAD 80
2	43900117	PANEL ALTA TEMPERATURA 1000X600X30 DENSIDAD 80

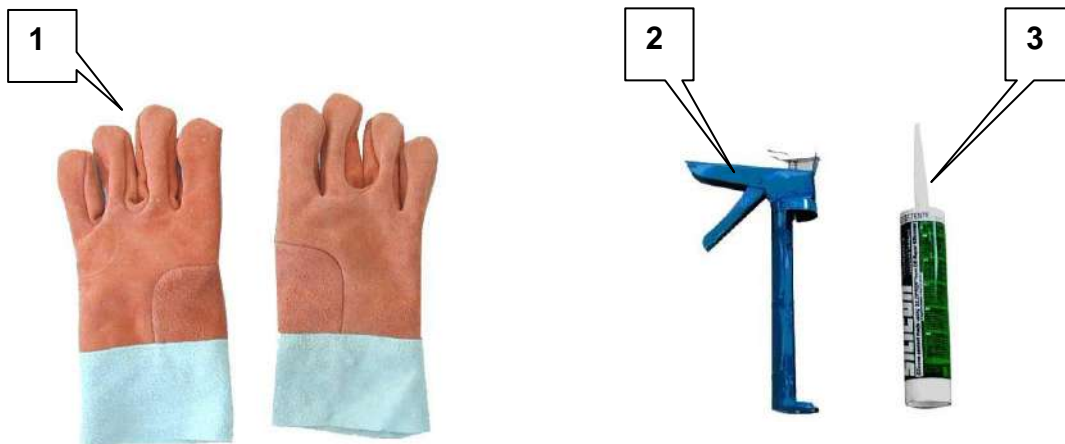

IT Accessori		
Pos.	Codice	Descrizione
1	54900007	GUANTI ANTICALORE
2	54900002	PISTOLA PER SILICONE
3	43900008	CARTUCCIA SILICONE TERMORESISTENTE

ENG Accessories		
Pos.	Code	Description
1	54900007	HEAT-RESISTENT GLOVES
2	54900002	SILICONE GUN
3	43900008	SILICONE HEAT-RESISTENT CARTRIDGE

FR Accessoires		
Pos.	Code	Description
1	54900007	GANTS RESISTENTS A LA CHALEUR
2	54900002	PISTOLET À SILICONE
3	43900008	CARTOUCHE RESISTENTE A LA CHALEUR DU SILICONE

ES Accesorios		
Pos.	Código	Descripción
1	54900007	GUANTES RESISTENTES AL CALOR
2	54900002	PISTOLA POR LA SILICONA
3	43900008	CARTUCHO RESISTENTE AL COLOR DE LA SILICONA

Apach

BAKERY *Line*

Equip Group

+7 495 234 00 33

<http://equip.me/>

<http://bakeryline.apach.it/>