

Contents

1. Information.....	3
1 Introduction.....	3
2 Safety.....	3
3 Electrical Installation Procedure.....	4
4 Plumbing Installation Procedure.....	4
5 Backflow Prevention.....	4
6 Maintenance.....	4
7 Descale Procedure.....	4
8 Limescale.....	5
9 Operating the Boiler for the First Time.....	5
10 Contact Details.....	5
2. Installation.....	6
3. Installing Filter.....	7
3. Operating Boiler.....	8
4. Service Set Up.....	9
1 Changing Temperature.....	9
2 Filter Mode.....	10
3 Changing from C/F.....	11
4 Heat Fill Selection.....	12
5. Cleaning & Maintenance.....	13
7. Troubleshooting.....	14



Information

Introduction

The information provided in this manual is intended to assist in the installation and maintenance of the MT range of hot water boilers. Please read the instructions carefully to prevent accidents and ensure an efficient installation. This manual is not a substitute for any safety instructions or technical data affixed to the machine or its packaging. All information in this manual is current at the time of publication and is subject to change without notice. The company accepts no responsibility for any damage or injury caused by incorrect or unreasonable installation and operation.

Safety

When using electrical appliances, basic safety precautions should always be followed to prevent the risk of fire, electric shock, burns, or other injuries or damages.

- Read all operating and safety instructions carefully.
- This appliance is not suitable for outdoor use.
- This appliance must be placed/installed on a horizontal flat stable surface.
- The ambient temperatures this appliance should operate within are 5 °C - 35 °C.
- Do not store the appliance in ambient temperature lower than 5 °C.
- This appliance is designed for use in self-service areas in which it can be attended to by trained personnel.
- Only the water hose supplied with the machine should be used to connect to the mains water supply
- The hose supplied with the boiler is non-toxic food quality. However, a hose is not a permanent connection. It is, therefore, advisable to switch off boiler and close the stopcock valve when boiler is not in use, e.g. overnight etc.
- If a non-fixed water connection is implemented, use only the water hose provided with the appliance, alternatively, if a fixed water connection is used it must be implemented using a non-detachable water hose.
- If the water hose is disconnected the seals should be replaced before re-connection.
- **Risk of scalding.** Beware of accidentally operating the water draw off tap especially when cleaning the front of the boiler.
- The utmost care has been taken in the manufacture and testing of this machine. Failure to install, maintain and / or operate this machine according to the manufacturer's instructions may result in conditions that can cause injury or damage to property. If in any doubt about the serviceability of the machine always contact the manufacturer or your own supplier for advice.
- This machine is not intended for use by persons (including children) with reduced physical, sensory, or mental capabilities, or lack of experience and knowledge, unless they have been given supervision or instruction concerning use of the machine by a person responsible for their safety.
- Children should be supervised to ensure that they do not play with the machine.
- In the event where any wires are damaged, such wires can only be replaced by qualified service technicians.
- CAUTION - Risk of fire and electric shock. Only to be used with manufacturer's specified power cord set. Marco p/n 1501487 (USA), 1501488 (EU), 1501489 (UK/Ire).
- This appliance should not be installed in an area where a water jet could be used to clean it.
- Access to the service area of the appliance is restricted to persons having knowledge and practical experience of the appliance and the relevant safety and hygiene requirements.

Information

Electrical Installation Procedure

Electrical specification: 2.8kW 200–230Vac 50Hz

When installing the machine, always observe the local regulations and standards. The appliance is supplied with a moulded power cord. A suitable mains power supply socket should be available within easy access of the appliance so that it can be disconnected easily after install.

Plumbing Installation Procedure

- Ensure that the equipment is installed according to local plumbing & water regulations.
- Mains water pressure required (limits): 100–500kPa, 0.1–0.5MPa (14.5–72.5psi).
- Fit a stop valve on a cold water line and attach a 3/4" BSP male fitting, (E.g. 3/4" x 1/2" or washing machine type stop valve).
- Turn on the water to flush any impurities, dust etc from the inlet hose and water pipe. Allow several litres through. Especially for new installations.
- Connect the hose to the inlet valve of the boiler. Make sure a sealing washer is fitted.
- Turn on water and check for leaks.
- NOTE: Using a non-food grade hose (e.g. a washing machine hose) will usually result in off tastes & smells in the water and can possibly be toxic.
- Do not connect the machine to pure reverse osmosis water or other aggressive types of water.

Backflow Prevention

This equipment must be installed with adequate backflow protection to comply with all applicable federal, state and local codes.

Maintenance

This machine has been designed to give many years of trouble free service. The only regular maintenance required is occasional de-scaling.

Cleaning

The exterior of these machines may be cleaned with a damp cloth and a light detergent.

Do not use abrasive cloths or creams, as this will spoil the finish of the machine.

Do not use a water jet or spray.

NOTE: Beware of accidentally operating the draw off tap when cleaning the front of the machine.

Limescale

In common with all water boiler manufacturers, service calls resulting from limescale are not covered by warranty. For units without a water filter fitting an external scale reducer is recommended, especially in hard water areas. This can reduce the build-up of scale but may not stop it altogether. The frequency that descaling is required depends on the local water supply; hard water areas need more attention. Descaling of the machine should be carried out by qualified service personnel.

Information

Operating Boiler For The First Time

1. Check that all installation procedures have been carried out, see the following page.
2. Ensure water valve is connected
3. Plug in the IEC connector to the boiler.
4. On models with a filter, connect the filter.
3. Plug boiler into suitable socket.
4. The boiler will power up.
5. The screen will show the software revision.
6. The machine will then fill with water and the display will flash between E-2 & the current temperature of the tank, until the water has reached the low level probe, then it will show the current water temperature.
7. The default temperature is 95°C.
8. Once the machine is up to temperature the boiler is now ready for use.

NOTE: Because the boiler is electronically controlled no priming is necessary. The element cannot switch on until a safe level of water is reached.

Installation

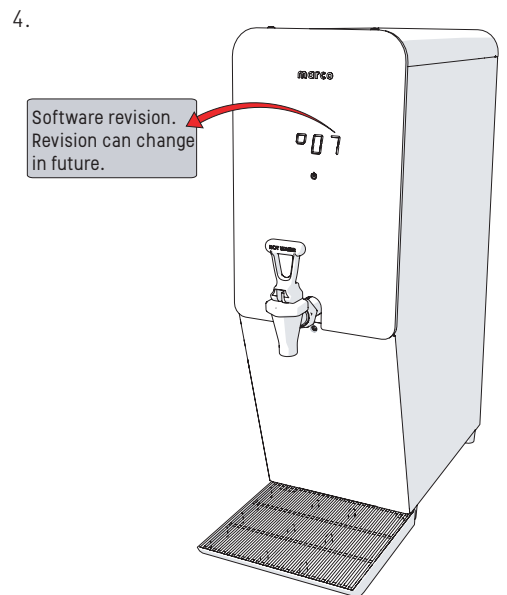
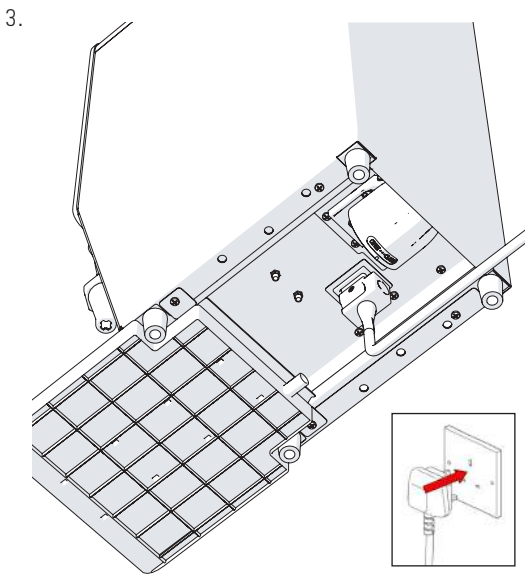
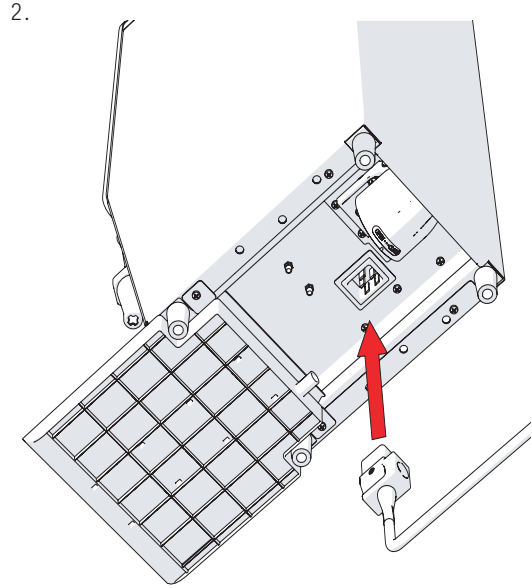
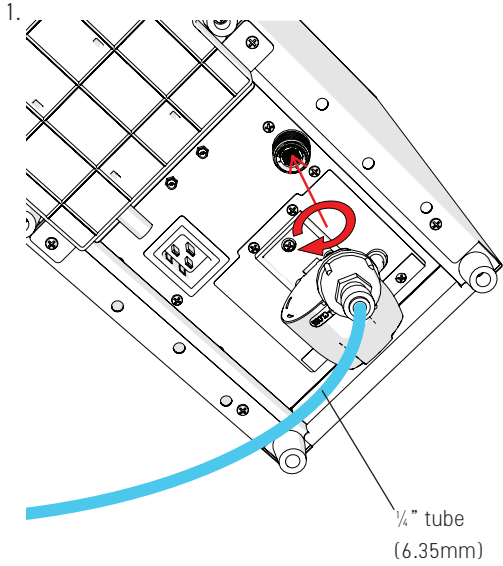

Installing Filter

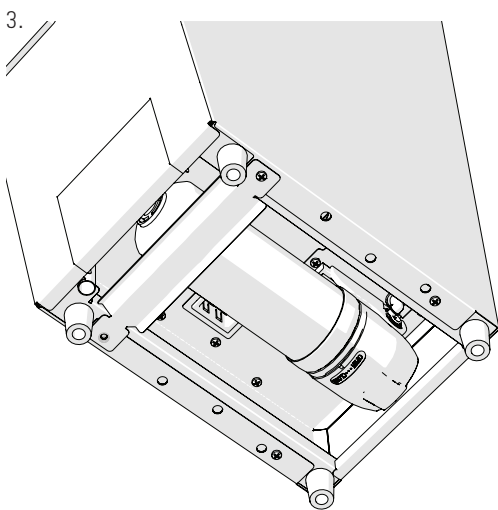
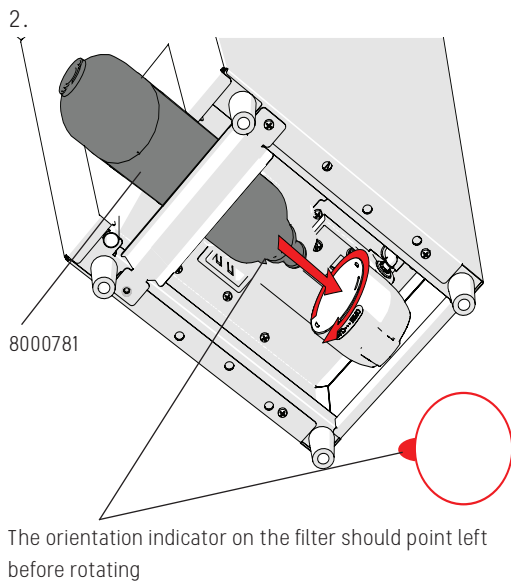

Operating Boiler

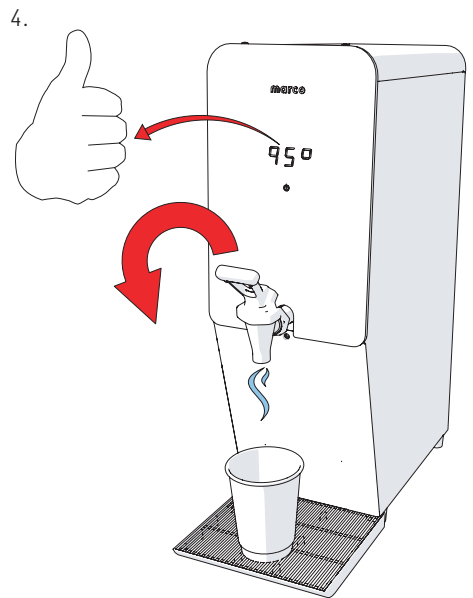
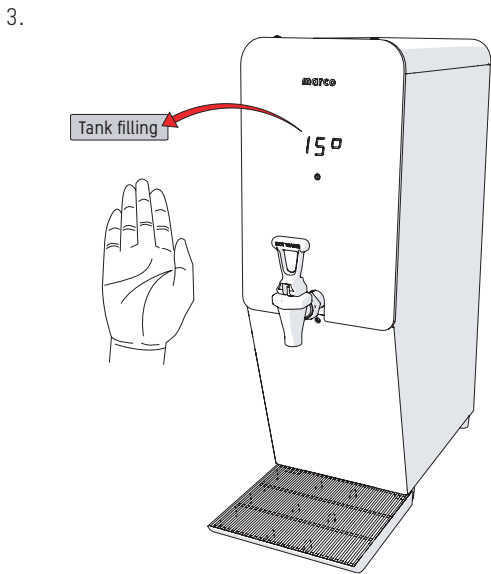
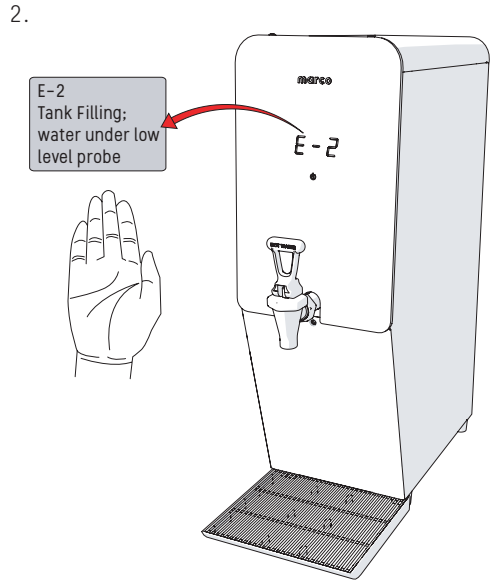
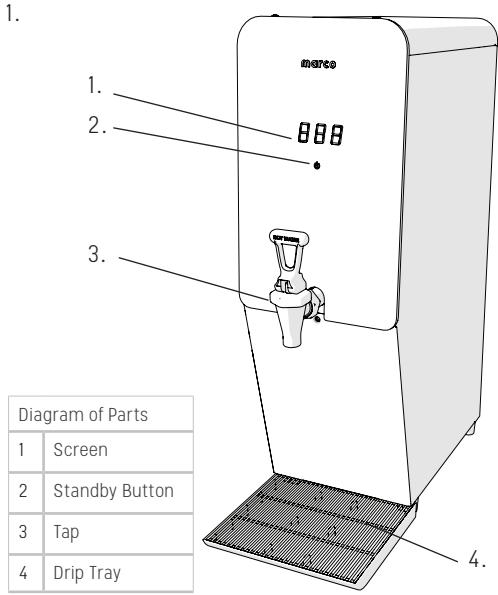

Service Set Up

Changing Temperature

1.

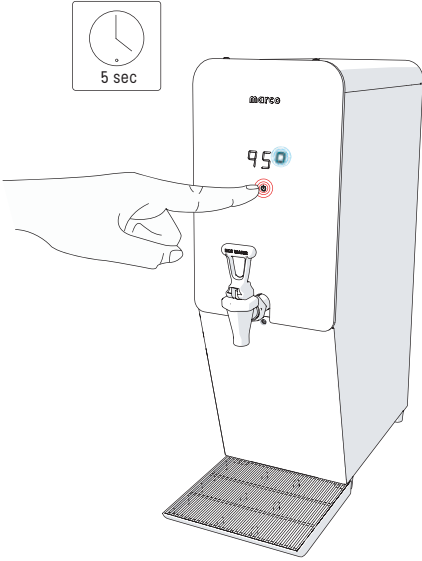

2.

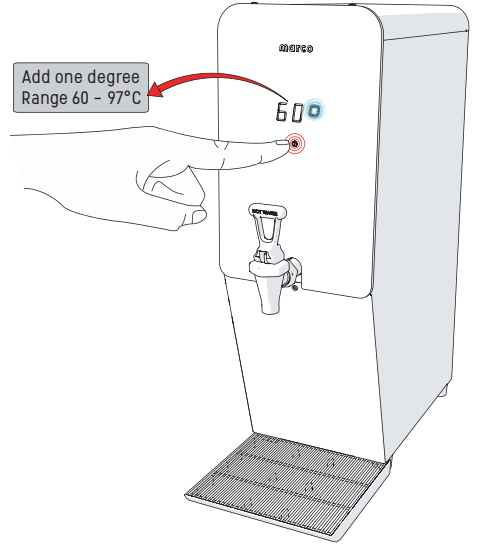

3.



Service Set Up

Filter Mode

1.

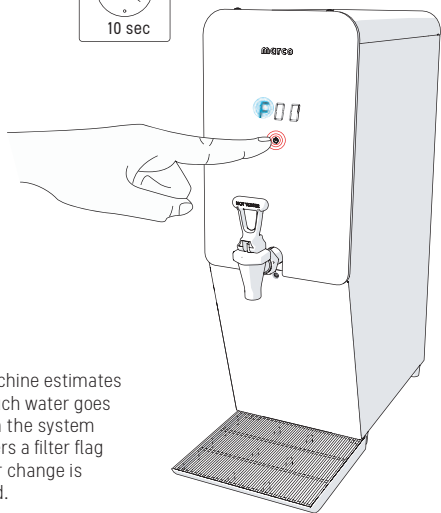

The machine estimates how much water goes through the system & triggers a filter flag if a filter change is required.

2.

Add 2 units.
Each unit is 200L.
Setting to "00"
disables the flag.

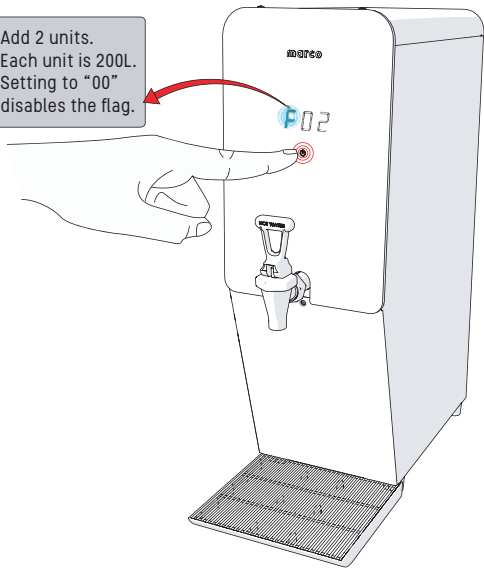

3.

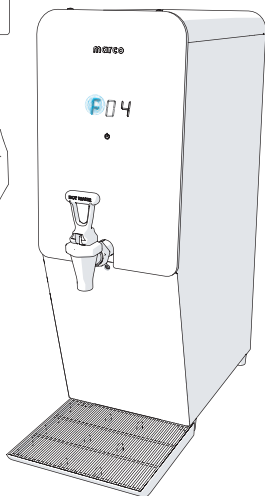

Service Setup

Changing from Celcius to Farenheit

1.

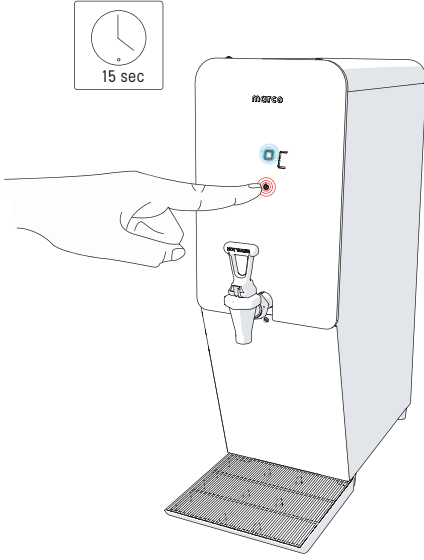

2.

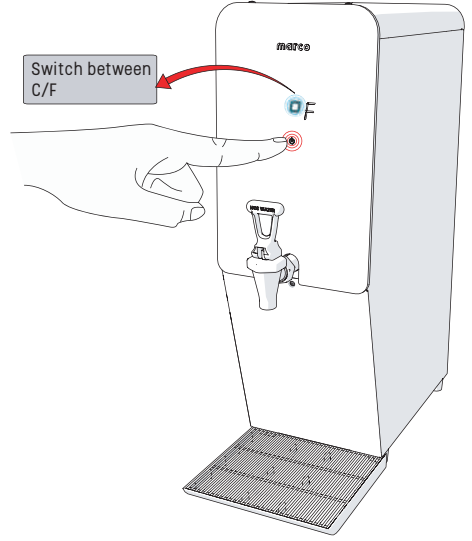

3.

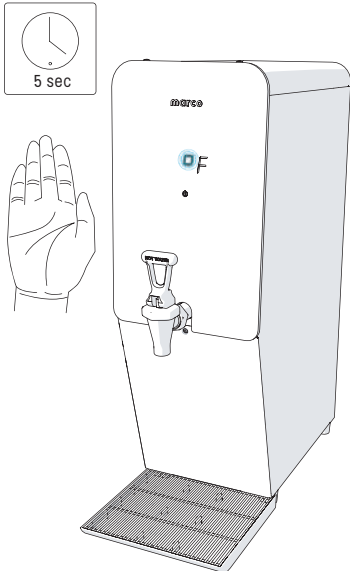

4.

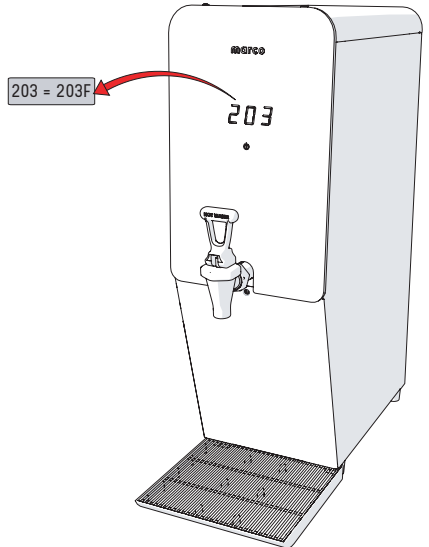

Service Set Up

Heat Fill Selection

1.

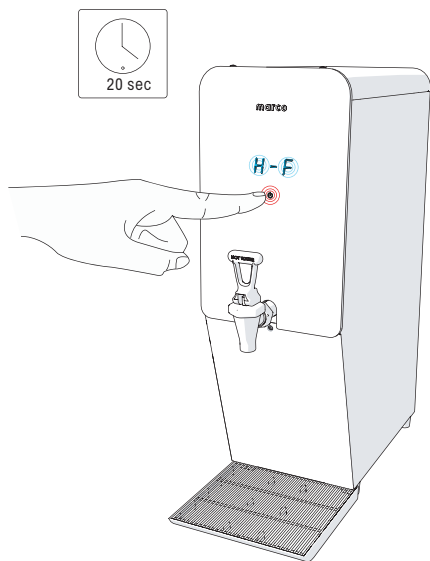

2.

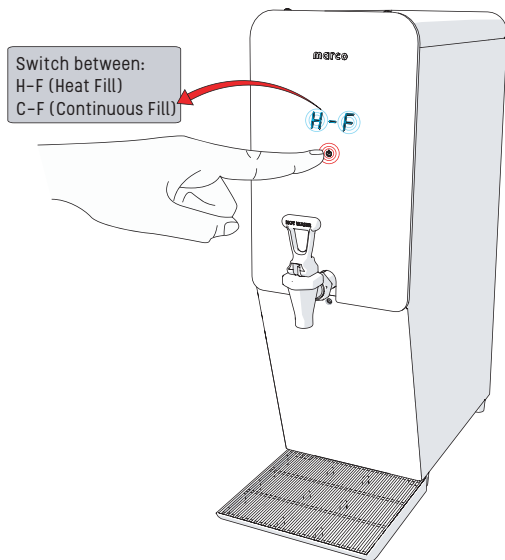

3.

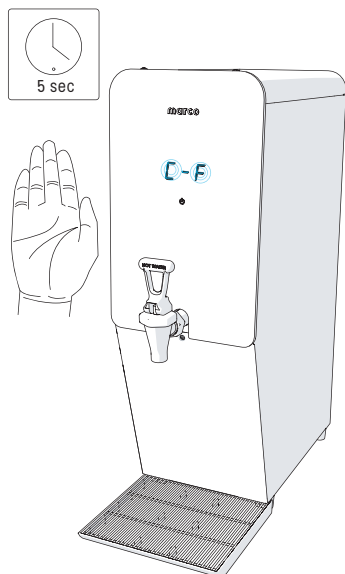

Heat Fill (default & recommended setting)

The inlet valve lets in a small fixed volume of water and the element turns on heating the water to the set temperature. This process is repeated until the water has reached the high level probe and the machine is up to temperature.

Continuous Fill

The inlet solenoid stays open until the water has reached the high level probe. Simultaneously the element stays on until the machine is up to the programmed set temperature.

Cleaning & Maintenance

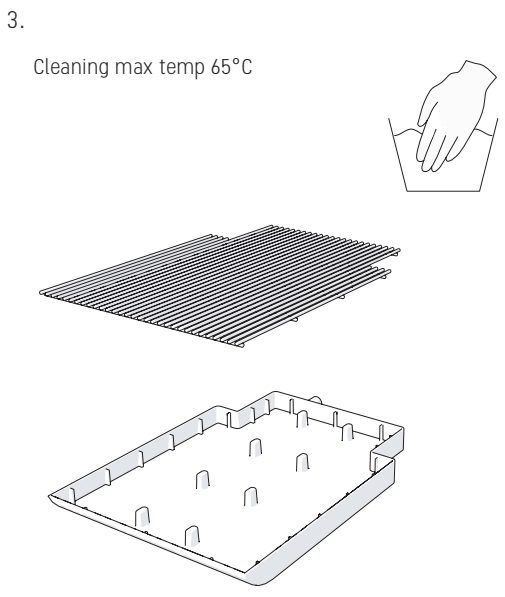
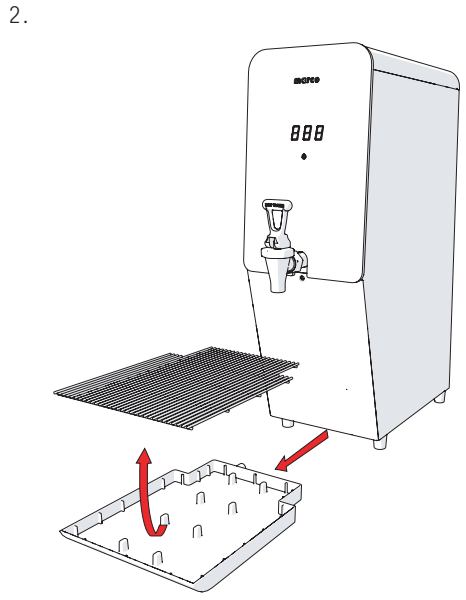
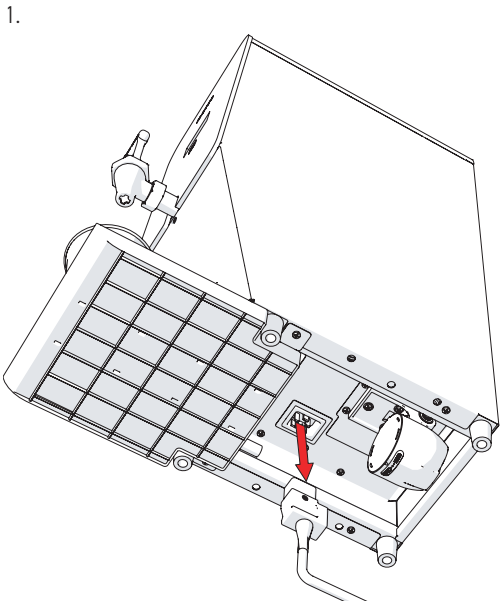

Troubleshooting

The screen of the boiler indicates various errors or problems with the machine. See diagnostic table below for further details.

Error	Description	Action
E-1	High level probe is detected but low level probe is not detected.	Descale machine & low-level probe. If it persists, call service agent. Check low level probe is wired. Check high & low level are not switched.
E-2	Low level probe not detected.	Wait for machine to fill. If water can be dispensed then the probe may be covered in limescale, -descale machine. If descaled and error persists then call service agent. Check low level probe is wired.
E-3	Temperature sensor (thermistor) is faulty, missing or not plugged in.	Call service agent. Thermistor has an open circuit.
E-4	Water is not heating	Element has failed, Call service agent. Check element for resistance which should be approx 19 Ohms
E-5	Temperature sensor (thermistor) is faulty	Call service agent. Thermistor has a short circuit.
E-6	No incoming water	Check water supply is turned on and mains pressure is above 1bar (14.5psi) If water supply is OK call service agent as the inlet valve has likely failed.

Contact Details

Marco Beverage Systems Limited.

74 Heather Road,

Sandyford Industrial Estate,

Dublin 18

Tel: +353 (0)1 295 2674

Fax: +353 (0)1 295 3715

email: sales@marco.ie

www.marco beveragesystems.com

