

serie
range
FRV



Morello Forni®

Forno rotante elettrico ventilato
Rotating electric convection oven



- 
 - Forno elettrico a convezione con platea rotante
 - Doppio sistema di riscaldamento indipendente a temperatura differenziata di volta e platea
 - Gestione termostatica delle temperature con controllo indipendente della forza convettiva
 - Gestione percentuale della potenza elettrica alle resistenze
 - Sistema di gestione automatico, senza intervento continuo dell'operatore
- Cupola e platea in materiale refrattario
- Coibentazione termica super efficiente per diminuire le perdite di calore
- Rotazione platea a velocità e direzione variabili, a regolazione manuale e controllo automatico
- Tre programmi di cottura impostabili per automatizzare e semplificare il lavoro dell'operatore
- Il sistema garantisce uniformità alla cottura
- Riduzione tempi di cottura con aumento della produttività
- Luce interna



- 
 - FRVs are electric rotating convection ovens
 - Dual temperature-based independent heating system for dome and bedplate
 - Thermostatic management with separate convective force control
 - Heating resistors electric power percent control
 - Automatic oven management, not requiring constant user intervention



- Refractory dome and bedplate
- Highly efficient thermal insulation to minimize heat losses
- Speed and direction variable bedplate rotation, with manual adjustment and automatic control
- Up to three baking programs can be set up to ease and automate operator's tasks
- The rotating system provides baking uniformity and shorter cooking times, increasing productivity
- Internal light



FRV125 CM Opus Incertum Gold

FORNO ROTANTE / ROTATING OVEN

le finiture della linea / range finishes • **FRV**

**CERTIFICAZIONI
CERTIFICATION**

costruiti e omologati
secondo le norme
*manufactured and certified
according to norms*



Mod./Ref.	Consumo massimo/ Consumption maximum	Mantenimento consumo/ Maintaining consumption	Capacità pizze Ø 30 cm./ Capacity pizzas Ø 30 cm.	Produzione oraria/ Productivity per hours
FRV100	14 KW	2,5 KW	6 pizze	90 pizze/h
FRV125	24 KW	5 KW	9 pizze	160 pizze/h

serie
range
FRV

Forno rotante
elettrico ventilato
*Rotating electric
convection oven*

FORNO ROTANTE / ROTATING OVEN

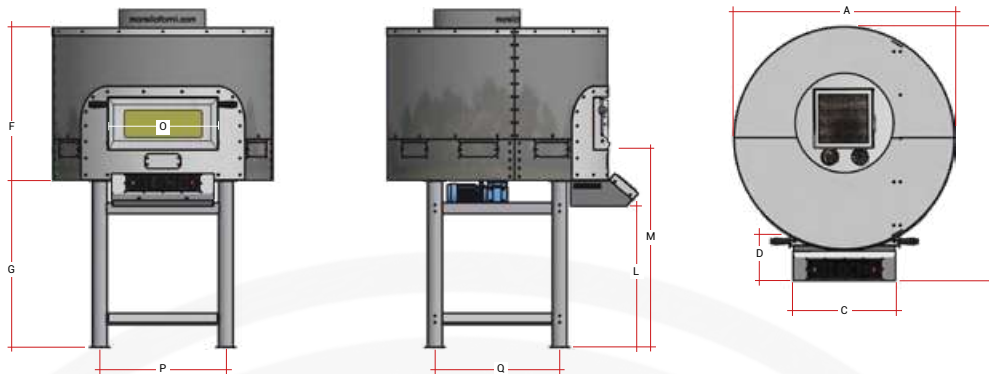

Mod./Ref.	A	B	C	D	F	G	L	M	O	P	Q	peso/weight (kg)
FRV100	120	147	56	33	95	90	72	112	56	70	70	650
FRV125	164	180	98	35	95	80	80	122	65	90	110	1550

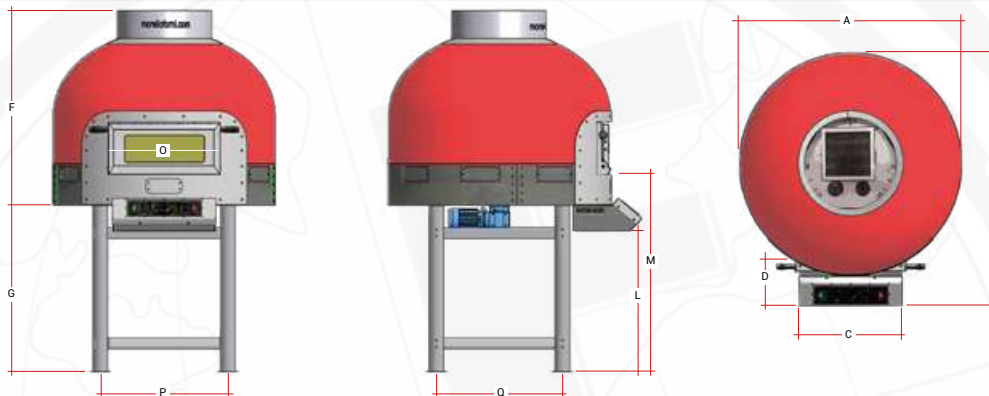

Mod./Ref.	A	B	C	D	F	G	L	M	O	P	Q	peso/weight (kg)
FRV100	120	147	56	33	106	90	72	112	56	70	70	650
FRV125	164	180	98	35	122	80	80	122	65	90	110	1850

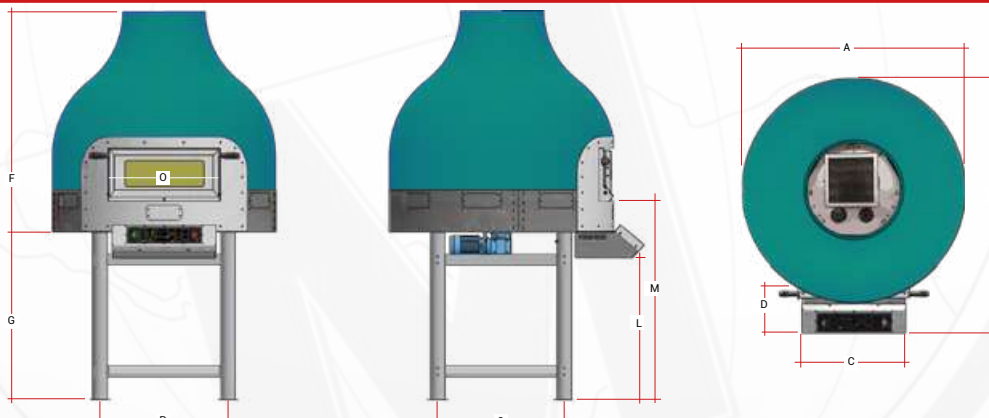

Mod./Ref.	A	B	C	D	F	G	L	M	O	P	Q	peso/weight (kg)
FRV100	120	147	56	33	116	90	72	112	56	70	70	650
FRV125	164	180	98	32	140	80	80	122	65	90	110	1900



alcune nostre finiture
some of our finishes



FRV 100 STANDARD



FRV 100 CM-V CRYSTAL COPPER



FRV 125 CB NERO MORELLO

MORELLO FORNI ITALIA Srl

Via B. Parodi, 35 - 16014
Ceranesi (Genova) - Italy
Tel. +39 010 7401194
Fax + 39 010 7492194
info@morelloforni.com

www.morelloforni.com



i nostri ricambi / our spare parts
parts.morelloforni.com