

MAR 78

Modular Ice Machine 570 kg

Item #:
Project:
Quantity:



FEATURES

- Scale ice machine, in split system" version; built-in unit. Storage bin not supplied, to be purchased separately.
- To be connected to condensing unit or central cooling system (low temperature).
- AISI304 Stainless steel evaporator and ice scraper blade. Redesigned evaporator compartment end-walls.
- Foodgrade ABS plastic water sump tray, easy remove for cleaning and sanitising.
- Electromechanical control panel. Electrical protections, rotation speed & reverse phase controls.
- Low- water sensor protection. Hermetic compressor. Storage bin thermostatic ice level sensor. Drive motor / gear reducer with V-Belt drive.
- Stainless steel panels in scotch-brite finish, with rounded corners, easy to remove for maintenance.
- Supplied w/expansion valve, solenoid valve, pressure regulating valve (KVP), heat exchanger.

Modular Ice Machine 570 kg



MAR 78
Scale ice
Residual water content 2%
Thickness 1 or 2 mm

CONDENSING SYSTEM

SPLIT

REFRIGERANT GAS

R404A
R452A

VOLTAGE V/Hz/ph

230/60/1
400/50/3N

RECOMMENDED BINS

Head	Bins		kg
	Bin	Weight	
MAR 78	●	UBH1100	553
	●	UBH1600	812
	●	UBH2250	1068
	●	SIS300	137 + 73
	●	SIS700	318 + 73
	●	SIS1350	613 + 73 + 73

LEGEND:

- ✓ : Perfect combination between ice maker and bin
- : Ice chute cut-out performed upon installation
- CBTxxxxxxx : need additional bin top

CERTIFICATIONS



OPERATING REQUIREMENTS

	Minimum	Maximum
Air temperature	10	43
Water temperature	5	38
Water pressure	1 bar (14 psi)	5 bar (70 psi)
Electrical voltage	-10	+10

IMPORTANT NOTICE:
Models and specifications are subject to change without notice.
This spec sheet is meant for commercial purpose only.
For technical documentation please refer to our service manuals.

Download our free **App Scotsman Ice**
Apple store
Google play
Windows store



www.scotsman-ice.it
www.scotsman-ice.com

MAR 78

Modular Ice Machine 570 kg

Item #:
Project:
Quantity:

Modular Ice Machine 570 kg

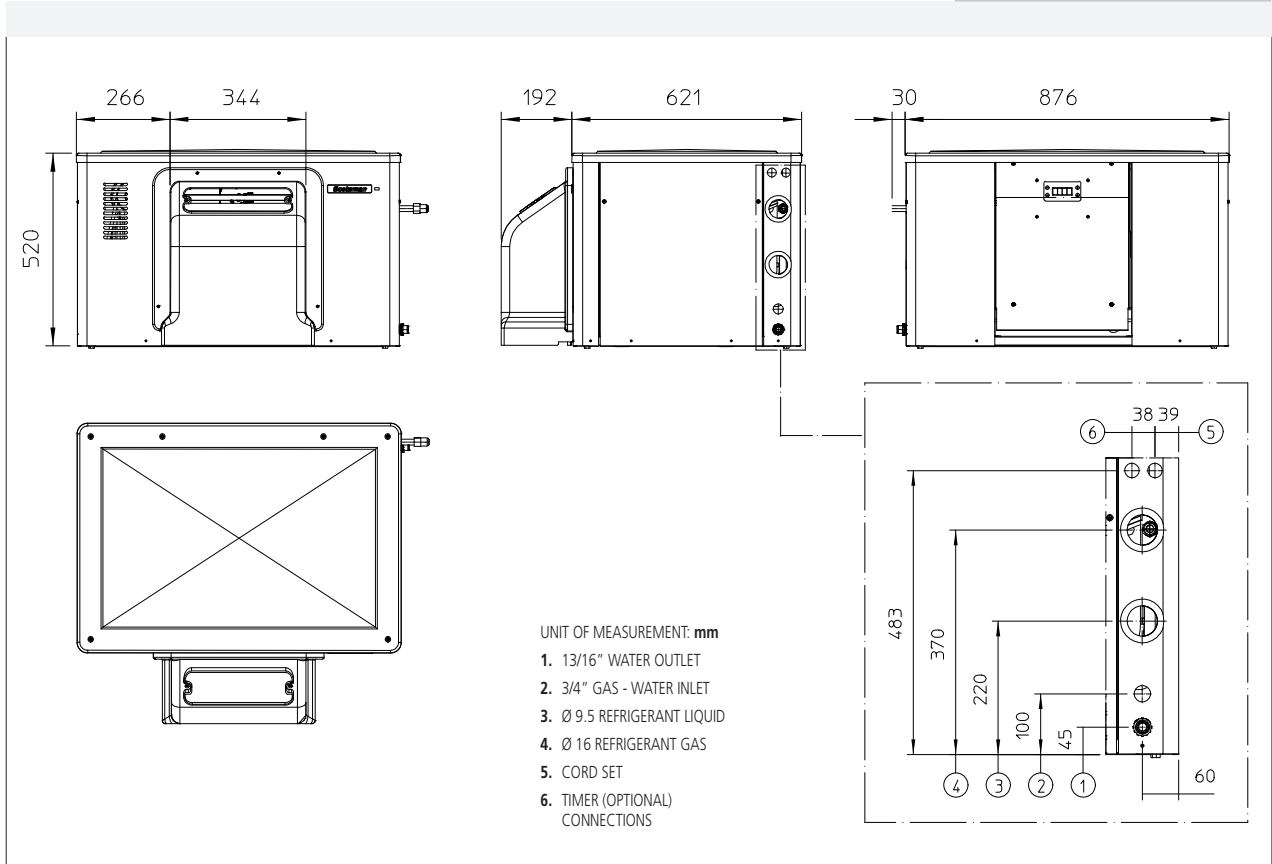

UNIT DATA		SHIPPING DATA		All data refer to R404A refrigerant models														
Size (W x D x H)	906 x 813 x 520 mm	Carton (W x D x H)	980 x 740 x 680 mm	Version	Voltage	24 h ice production kg °C Amb. / °C Water						Energy consumption (*)		Water usage (*)	Instant power	Compressor	Circuit wires	Max. fuse size
Net weight	95 kg	Weight	112 kg			10°C/10°C		21°C/10°C		32°C/21°C		kWh/100 kg	kWh/24h	l/h	W	W	No. x 0mm²	A
				MAR 78 SPLIT	400/50/3N	570	510	0	0	0	0	1.2	9.6	16.7	395	2950	5 x 2.5	10
				MAR 78 SPLIT SW	400/50/3N	0	400	0	0	0	0	1.2	9.6	16.7	395	2950	5 x 2.5	10
				MAR 78 SPLIT	230/60/1	0	0	0	0	0	0	1.2	9.6	16.7	395	2950	3 x 2.5	10
Compressor:	(Te -18.0°C; Tc +40.0°C)																	
Compressor SW:	(Te -20.0°C; Tc +40.0°C) Made of AISI stainless steel with antispash; without heat exchanger, solenoid valve, KVP valve and electrical panel.																	

(*) Data refer to 32°C Amb. / 21°C Water temperature conditions