



**DRY AGER**  
SUPERIOR BEEF



**Operating Instructions**  
**DRY AGER® DX 500®**

**THE ORIGINAL  
PERFECT FOR YOUR HOME**



**MADE IN GERMANY, FOR 20 KG MEAT  
FITS IN EVERY KITCHEN**

for dry-aged beef, pork, ham and salami.





## DRY AGING



Dry Aging is no longer a mystery. You too can produce succulent and tasteful meat for yourself with the

### DRY AGER DX 500®

When this technique is used, the result is a quality piece of meat that brings out a natural, but a more intensive flavour. The texture of the matured meat is tender, yet firm and has a perfect bite.

You will notice that when the Dry Aged meat is grilled or pan fried, there are hardly any meat juices and that the fat surrounding it gives off a spicy aroma.



The founders of the DRY AGER Manufactur wish you lots of joy and pleasure at dryaging.

Christian, Aaron and Manfred Landig

### MEAT QUALITY

The best meat recognised for Dry Aging is rib-eye on the bone. It is always best to purchase from a dealer who sources their meat from a good quality abattoir.

The younger the animal the better the result. It is always recommended to buy a piece of meat that has a good fat content and a high rate of internal marbling. It is advisable to mature the meat on the bone either hanging or in the largest possible joints. The reason for this is to minimise the pure meat exposed to the air, reducing weight loss.

The Dry Aging period is recommended for at least 21 days, then the maximum tenderness is reached. Thereafter, only the flavour becomes more intense. Please note : A maturing period of up to 6 weeks is possible. The hygienic handling of food should always be addressed for best results. When the process is complete, the thin crust is trimmed off ready to be de-boned or cut into steaks.

## Disposal notes

The appliance contains reusable materials and should be disposed of properly - not simply with unsorted household refuse. Appliances which are no longer needed must be disposed of in a professional and appropriate way, in accordance with the current local regulations and laws.



When disposing of the appliance, ensure that the refrigerant circuit is not damaged to prevent uncontrolled escape of the refrigerant it contains (data on type plate) and oil.

- Disable the appliance.
- Pull out the mains plug.
- Cut through the connection cable.



### WARNING

Danger of suffocation due to packing material and plastic film! Do not allow children to play with packaging material. Take the packaging material to an official collection point.

## Description of the appliance

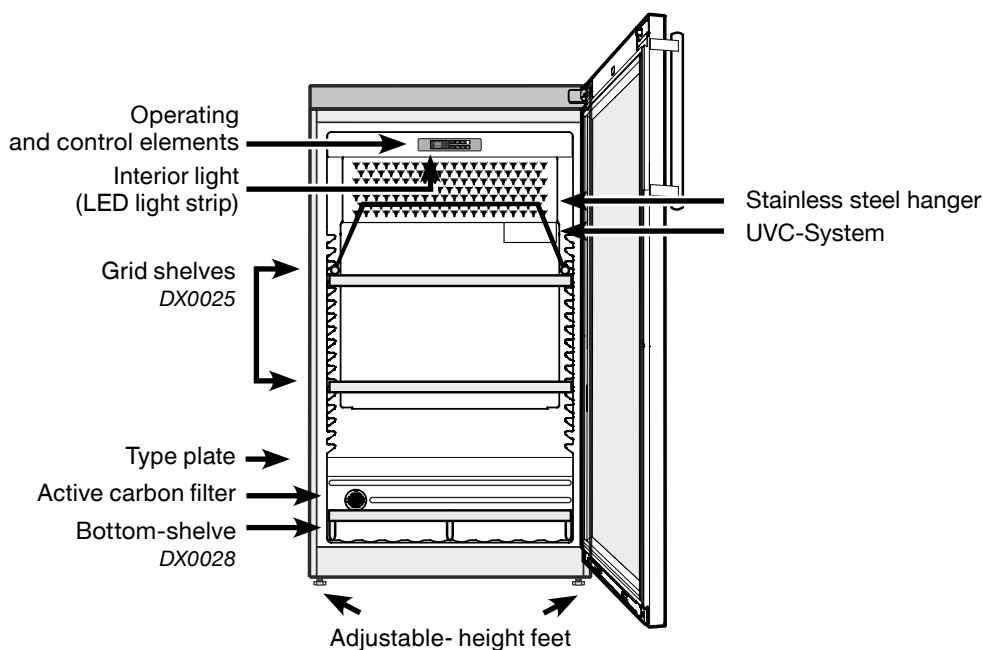

## Range of Appliance Use

The unit is only suitable for the cooling of meat or food in a home, commercial environment or similar.

All other types of use are not permitted. The unit is not suitable for the storing and cooling of medicines, blood plasma, laboratory preparations or similar - Medical Devices Directive 2007 /47 / EC with regards to the underlying materials and products . Any misuse of the appliance may result in damage to the stored goods or spoilage . Furthermore, the appliance is not suitable for use in hazardous areas.

## Saving Energy

- Always ensure good ventilation. Do not cover ventilation openings or grill.
- Always keep fan louvres clear.
- Do not place appliance in areas of direct sunlight or next to a stove, heater or similar object.
- The energy consumption depends on the installation conditions, e.g. the ambient temperature.
- Keep the time the appliance is open to a minimum. Accumulated dust increases the energy consumption:
- Once a year, Hoover the refrigerating unit together with the metal grill of the heat exchanger at the back of the appliance.

## Integrated systems

### HUMICONTROL®

electronic humidity controller from 60% to 90%  
(no water connection necessary)

### DX AIRREG®

optimal airflow, activated carbon filter & sterilization

### LED LIGHTING DX

the light spectrum does not contain any ultraviolet radiation, the result is a minimum of heat generated and will not affect the core meat temperature.

### DEFROST AUTOMATIC, AUTOMATIC CONDENSATION EVAPORATION

### OPTIC AND ACUSTIC ALARM ALERT

### LOCKABLE DOOR, REVERSIBLE DOOR

### CAN BE INTEGRATED

### MAGNETIC DOOR SEAL



**DX 500®**

Dry Aging hanging  
2x half saddles  
( our suggestion! )



**DX 500®**

Dry Aging of  
cuts on shelves  
( more wastel! )



## Starter-Tips

- I** Clean the inside of the Dry Ager with disinfectant, which shouldn't be aggressive. Tip: DRY AGER SPECIAL CLEANER, Art. Nr. Z33145
- II** If ordered: unpack the salt blocks and remove the foil. Put the salt blocks in the stainless steel tray and place the tray in the middle of the fridge. Please check every 2 -3 days if there is any remaining water on the salt blocks, if so, please remove the water.
- III** Plug in the device in a 220-240 V socket.
- IV** The temperature and humidity are already setted on 1,5 °C and 82% humidity which are the perfect settings for dry aging beef & pork.
- V** The meat for the dry aging must be fresh, perfect would be max. 5 days after slaughtering. Even vacuum matured meat can be used, but for a maximum of 14 days (please remove foil)
- VI** Our recomendation for the best dry aged beef: use meat from a young cow with an ordinary fat cover plus good marbling.
- VII** Hang the complete back on the hangers of your Dry Ager or put the individual cuts on the shelves.
- VIII** Load capacity: max. 2x half strip loins on the bone with a length of 0,5 m , therefore you will need 2 hangers.
- IX** Load capacity with shelves: max. 20 kg individual pieces or cuts will fit on our shelves.
- X** When maturing individual cuts on the shelves, pay attention on a protective fat layer which prevents too much wastage and if possible let it mature on the bone. Ideal size aprox. 2 – 4 kg / cut
- XX** Please wear protective gloves at each contact with the meat, no one should ever touch the meat without gloves!
- XII** The perfect maturing time is between 25 – 28 days, but more than 4 weeks is also possible.



## Safety Instructions and warnings

- To prevent injury or damage to the unit, the appliance should be unpacked and set up by two people.
- In the event that the appliance is damaged on delivery, contact the supplier immediately before connecting to the mains.
- To guarantee safe operation, ensure that the appliance is set up and connected as described in these operating instructions.
- Disconnect the appliance from the mains if any fault occurs. Pull out the plug, switch off or remove the fuse.
- When disconnecting the appliance, pull on the plug, not on the cable.
- Any repairs and work on the appliance should only be carried out by the customer service department, as unauthorised work could prove highly dangerous for the user. The same applies to changing the mains power cable.
- Do not allow naked flames or ignition sources to enter the appliance. When transporting and cleaning the appliance, ensure that the refrigerant circuit is not damaged. In the event of damage, make sure that there are no ignition sources nearby and keep the room well ventilated.
- Do not stand on the plinth, drawers or doors or use them to support anything else.
- This appliance can be used by children of 8 years old and over, and also by persons with restricted physical, sensory or mental capacity or lack of experience and knowledge, if they are supervised or have been instructed on safe use of the appliance and understand the resulting risks. Children must not be allowed to play with the appliance. Cleaning and user maintenance must not be carried out by children without supervision.
- Avoid prolonged skin contact with cold surfaces or chilled/frozen food. This could cause pain, numbness and frostbite. In the case of prolonged skin contact, protective measures should be taken, e.g. gloves should be worn.
- Do not consume food which has been stored for too long, as it could cause food poisoning.
- Do not store explosives or sprays using combustible propellants such as butane, propane, pentane, etc. in the appliance. Electrical components might cause leaking gas to ignite. You may identify such sprays by the printed contents or a flame symbol.
- Do not use electrical appliances inside the appliance.
- If you have a lockable appliance, do not keep the key near the appliance or within reach of children.
- The appliance is designed for use in enclosed areas. Do not operate the appliance outdoors or in areas where it is exposed to water or damp conditions.
- The LED light strip illuminates the interior of the appliance. It is not suitable for lighting a room.

- When transporting or operating the appliance at an altitude of more than 1500 m above sea level, the glass pane in the door can break due to the reduction in air pressure. Broken fragments are sharp-edged and can cause serious injury.

## Climate rating

The climate rating indicates the room temperature at which the appliance may be operated in order to achieve full refrigeration performance.

The climate rating is indicated on the type plate.

The position of the type plate is shown in the section entitled

### Description of the appliance.

Climate rating	Room temperature
SN	+10 °C to +32 °C
N	+16 °C to +32 °C
ST	+16 °C to +38 °C
SN-ST	+10 °C to +38 °C
T	+16 °C to +43 °C
SN-T	+10 °C to +43 °C

## Do not operate the appliance outside the specified room temperature range.

## Setting up

- Avoid positioning the appliance in direct sunlight or near cookers, radiators and similar sources of heat.
- The floor on which the appliance stands should be horizontal and level. Compensate for uneven floors with the adjustable feet.
- **Do not cover ventilation openings or grill..**



- Standard EN 378 specifies that the room in which you install your appliance must have a volume of 1 m<sup>3</sup> per 8 g of R 600a refrigerant used in the appliance, so as to avoid the formation of inflammable gas/air mixtures in the room where the appliance is located in the event of a leak in the refrigerant circuit. The quantity of refrigerant used in your appliance is indicated on the type plate on the inside of the appliance.

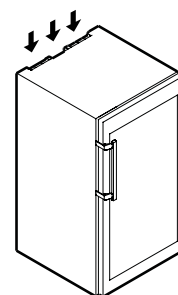

- Always install the appliance directly against the wall.
- Place the appliance in its final position at the place of installation. Extend the adjustable foot at the bottom hinge bracket until it rests on the floor and then make a further 90° turn.

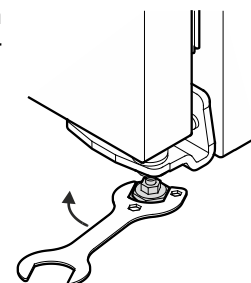

## Dimensions DX 500®

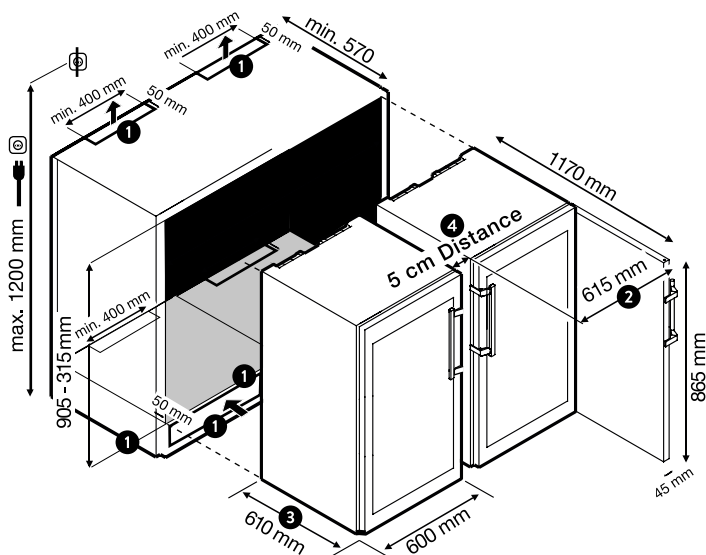
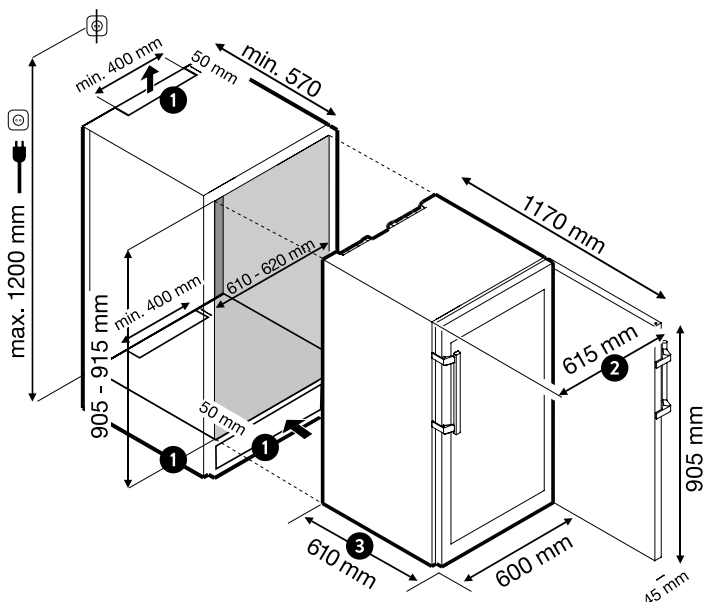
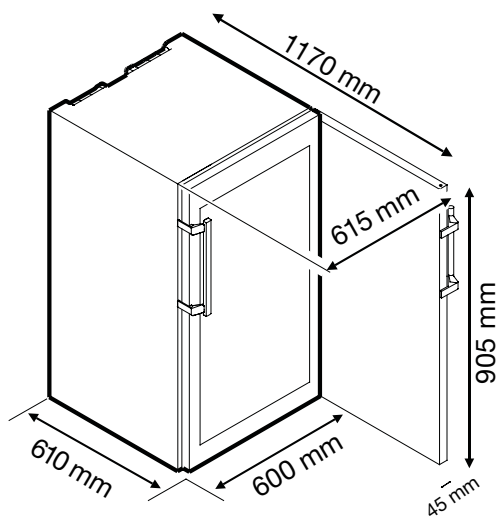

- ❶ Required ventilation shafts are absolutely necessary.  
**Minimum size: 200 cm².** Possible on the side or at the back.
- ❷ Overall dimension with open door: **615 mm.**
- ❸ Overall dimension body + door (protruding): **610 mm.**
- ❹ Covering of distance possible by DRY AGER moulding  
Available as an accessory in our shop: [www.dry-ager.com/shop](http://www.dry-ager.com/shop).

## Electrical connection

Only operate the appliance with alternating current (AC). The permissible voltage and frequency are indicated on the type plate. The position of the type plate is shown in the section entitled **Description of the appliance**. The socket must be properly earthed and protected by a fuse.

The tripping current of the fuse must be between 10 A and 16 A.

The socket must not be situated behind the appliance and must be easily accessible.

Do not connect the appliance using an extension cable or extension socket.

Do not use stand-alone inverters (conversion of direct current to alternating current/threephase current) or energy-saving plugs. Risk of damage to the electronic control system!

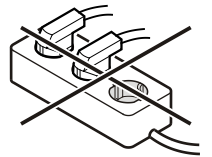

## Interior Light

The interior of the appliance is lit by an LED light strip at the top of the interior container.

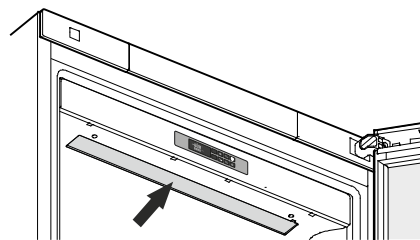

The light intensity of the LED light corresponds to laser class 1/1M.

### ⚠ Important

If the cover is removed, do not look directly at the light through optical lenses from close distance. This can damage your eyes.

## Safety lock

The lock in the appliance door is equipped with a safety mechanism.

### Locking the appliance:

- Insert the key as shown by arrow 1.
- Turn the key 90°.

To unlock the appliance, the same procedure must be repeated.

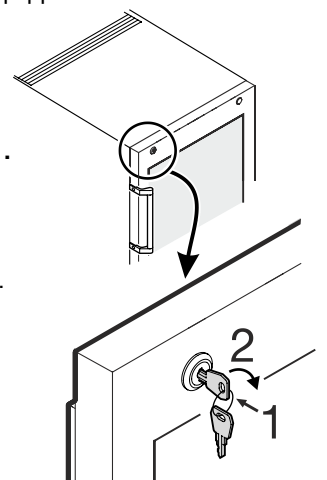



Ihr **DRY AGER DX 500®** is ready to use.  
We recommend the following settings for dry aging beef

**Temperature: 1,5°C**

**Humidity: 82 %**









**The activated carbon filter and UVC lamp should be replaced annually for optimum performance.**

Before reaching the lifetime a maintenance message appears in the message display, see page 9.

**Mehr Infos dazu unter: [info@dry-ager.com](mailto:info@dry-ager.com) | Tel. 075 81/4 89 59-0**

### Operating and Control Settings









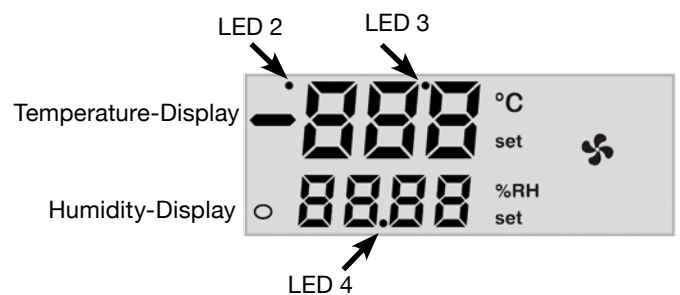

-  View / change the temperature setting (SET\_TEMP)
-  View / change the humidity setting (SET\_RH); Select or confirm a parameter during programming
-  Increases the displayed value  
On / Off Button for the UVC disinfection  
Press the button for a minimum of 5 sec
-  Decreases the display value  
Press and hold button for 3 seconds:  
Start manual defrost.
-  On / Off Button interior lighting
-  Power On / Off switch

### Key combination:

 +  Lock and seal keyboard

### Display and Symbols



LED / SYMBOL	MODE	FUNCTION
LED 4	ON	Standby
°C	ON	°C-Unit
°F	ON	°F-Unit
	ON	Cooling
	FLASHING	Delay cool
LED 3 	ON	defrost active
LED 3 	FLASHING	defrost
	ON	Heating active
set	FLASHING	default level for the temperature setting (Temp.)
	ON	Acoustic alarm
	ON	Fans running
%RH	ON	RH% -Humidity
LED 2	ON	UVC-Desinfection active
set	FLASHING	default level for the humidity setting



## Control ON and OFF

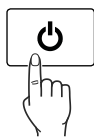

Press the button once for 5 seconds and the OFF symbol is displayed. The LED 4 (= standby) The compressor is turned off. All relays are deactivated. Press the button again and the compressor will restart.

## Locking and unlocking Keypad



1. Press ▼ and ▲ and hold together, for a minimum of 3 seconds, POF appears for a few seconds (POF = OFF parameter)

2. Thereafter, only displayed setting can not be changed. Furthermore, the MIN and MAX values can be viewed. The ON / OFF switch can be further activated.

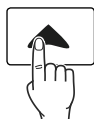

UNLOCK

Press ▼ and ▲ hold the two keys for a minimum of 3 seconds.

## Setting temperature

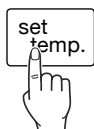

1. Press SET key: The set value is displayed and the LED's flash

2. Now to change the settings, within 10 seconds, use the ▼ and ▲ arrow keys

3. To confirm press SET button or wait 10 seconds

## Start manual defrost



Hold down button for a min. 2 seconds  
The manual defrosting starts.

Is indicated through LED3.

## Turn On / Off UVC Desinfection

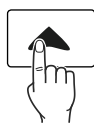

Press the button for at least 5 sec.  
Is indicated through LED2.

## Error Messages

Message	Reasons for error messages	Outputs
"P1"	Room sensor error	Cooling and Heating OFF
"P2"	Evaporation temperature sensor Failure	Defrost by time
"P3"	Humidity Sensor error	moisture control OFF
"HA"	High temperature alarm	regulation unaffected
"LA"	Low temperature alarm	regulation unaffected
"HHA"	HIGH humidity alarm	regulation unaffected
"LHA"	LOW humidity alarm	regulation unaffected
"dA"	Door alarm	regulation unaffected

Displays the alarm message until the alarm conditions exist. All alarms are displayed alternately with the room temperature except for the P1. EE can be acknowledged by pressing any key "rSt" for 3 seconds in the display, then returns to normal operation.

## Acknowledgement of the acoustic alarm

The audible alarm can be (optional) switched off by pressing any key.

## Alarm acknowledgement

Message P1, P2 and P3 after about 30 seconds; after correction or troubleshooting, the error message disappears automatically. Check probe sensor before replacing. Check connections. Temperature alarms HA and LA will automatically reset once the normal temperature is reached or when the defrost starts. DA goes off when the door is closed. External alarms EAL and BAL are disabled after the digital input. PAL acoustic alarm: Through Device Turning off or standby ON / OFF.

Humidity alarms HHA and LHA are acknowledged automatically when normal range has been reached.

## Maintenance information

Information	Reason
"UVC"	Lifetime of UVC-bulb and active carbon filter cartridge are reached.

Please order the Dry Ager Service Kit and change the UVC bulb, Art. DX0010 and Active Carbon Filter Cartridge, Art. DX00110. After exchanging you can reset the information:

1. Press ▼ and **SET % RH** and hold the keys for a minimum of 2 sec.
2. Select with button ▼ Parameter UcH.
3. Press button **SET % RH**. The set value is displayed and value is flashing.
4. With button ▼ set the value to „0“.
5. Confirm with button **SET % RH**.
6. After 1 minute the display switches automatically in standard display.

## Air exchange with activated charcoal filter

Before reaching the lifetime a maintenance message appears in the message display, see page 9.

### Changing the filter:

Take the filter by the handle. Turn it 90° to the left or right and remove.

### Inserting the filter:

Insert with the handle in a vertical position. Turn it 90° to the left or right until it clicks into place.

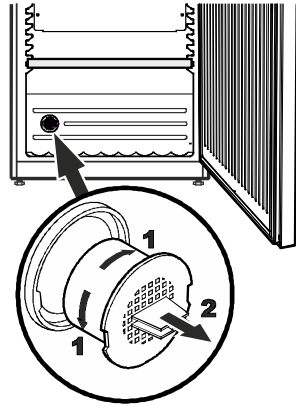

## Cleaning

Before cleaning always switch off the appliance. Pull out the mains plug or remove/unscrew the fuse.

- Clean the inside and outer walls with lukewarm water and a little detergent. Do not use abrasive or acid cleaners or chemical solvents.
- Use a glass cleaner to clean the glass surfaces and a commercially available stainless-steel cleaning agent for the stainless-steel surfaces.

### Do not use steam cleaners because of the risk of injury and damage.

- Ensure that no cleaning water penetrates into the electrical components or ventilation grill.
- Do not damage or remove the type plate on the inside of the appliance. It is very important for servicing purposes.

## Malfunctions

You may be able to rectify the following faults by checking the possible causes yourself.

### • Appliance does not function:

- Is the appliance switched on?
- Is the plug correctly fitted in the mains socket?
- Is the fuse intact?

### • Loud running noise:

- Is the appliance set up firmly on the floor?
- Does the appliance cause nearby items of furniture or objects to vibrate? Please note that noises caused by the refrigerant circuit cannot be avoided.

### • The temperature is not low enough:

- Is the temperature setting correct (see "Setting the temperature")?
- Does the separately installed thermometer show the correct reading?
- Is the ventilation system working properly?
- Is the appliance set up too close to a heat source?
- If the backwall is iced, please defrost the Dry Ager overnight.

### • The condensation freezes or does not expire in the defrost water channel?

- Clean the drain opening on the right side with a suitable object

If none of the above causes apply and you cannot rectify the fault yourself, contact the nearest customer service department stating the type designation ①, service number ② and appliance number ③ as indicated on the type plate.

The position of the type plate is shown in the section entitled Description of the appliance.

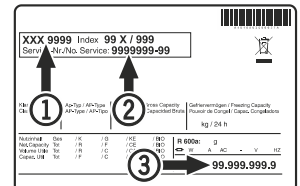

## Changing over door hinges

Door hinges should only be changed by a trained expert. Changing the door hinges must be done by two people.

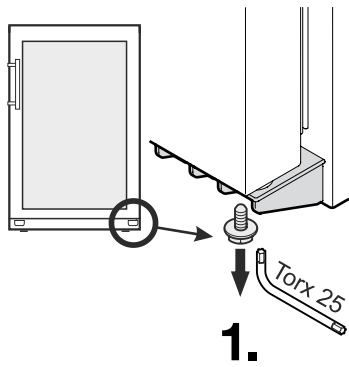

1. Unscrew the screw from the hinge angle at the bottom.

2. Remove the cover plate.

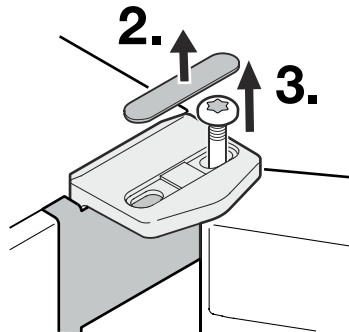
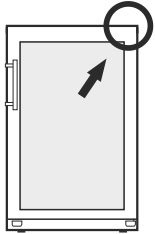

### Important note

The door must be held by one person due to the high weight.

3. Unscrew the bearing bolts from the upper hinge angle.

Remove door.

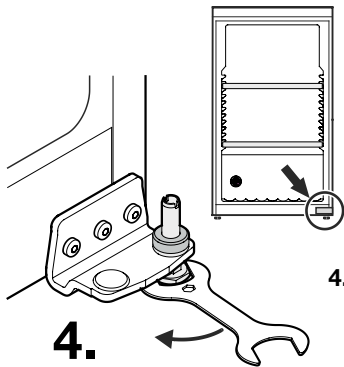

4. Loosen the adjustable foot with the enclosed wrench.

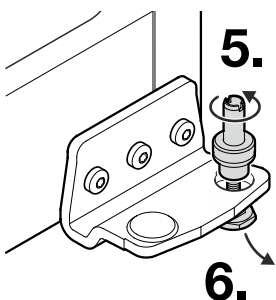

5. Pull the bolt upwards and unscrew the adjusting foot.

6. Pull the adjustable foot downwards.

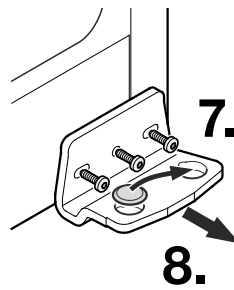

7. Unscrew the hinge angle.

8. Put the cover plate to the opposite side.

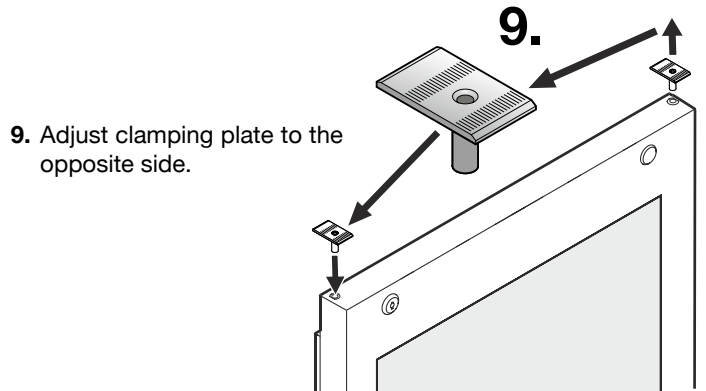

9. Adjust clamping plate to the opposite side.

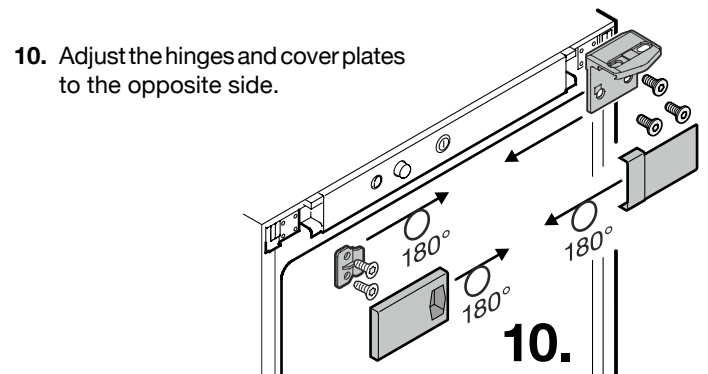

10. Adjust the hinges and cover plates to the opposite side.

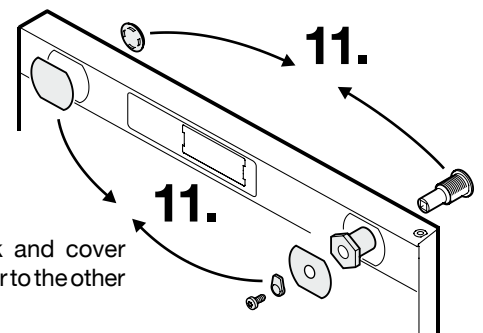

11. Adjust the lock and cover plates in the door to the other side.

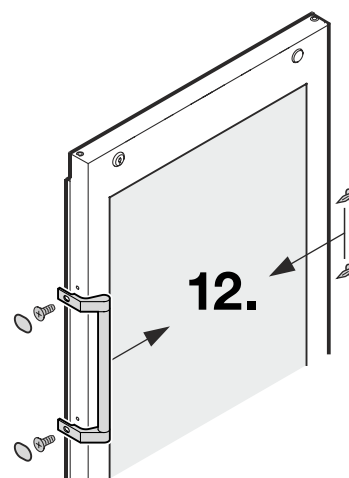

12. Adjust the handle and plugs to the opposite side.

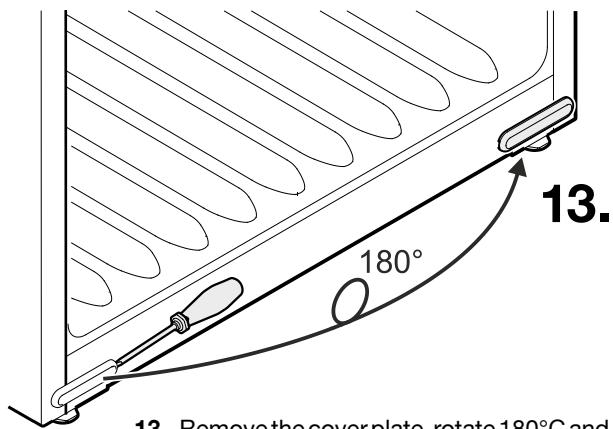

**13.** Remove the cover plate, rotate 180°C and reinsert on the opposite side.

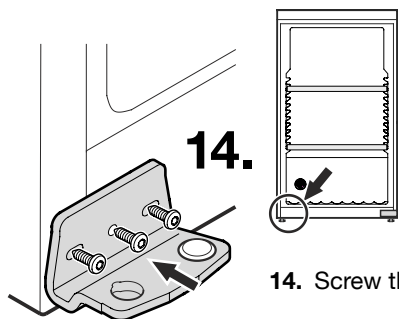

**14.** Screw the hinge angle.

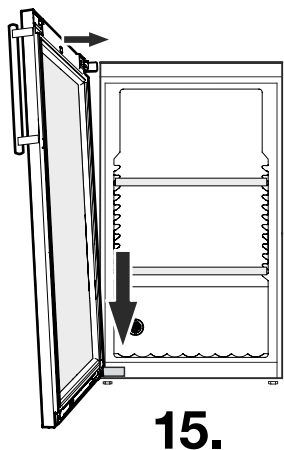

**Attention**  
the door must be held by another person!

**15.** Place the door on the bolt and guide it to the top of the hinge.

**15.**

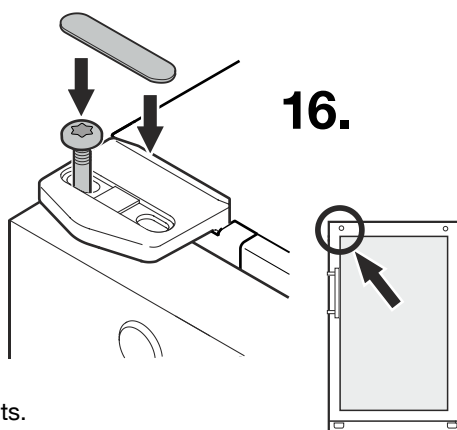

**16.** Insert bearing bolts.

Align the door sideways and tighten the bearing bolts.

Reinstall the cover plate.

## Technical Data



### DRY AGER DX 500

Art. Nr. DX0500

Internal Dimensions 71 x 50 x 43 cm (H x B x T)

External Dimensions 90 x 60 x 61 cm (H x B X T)

Internal Capacity/Net 147 / 132 Liter

Voltage 230 V

Max. 190 W / 1,0 A / 220-240 V / 50 + 60 Hz

Power consumption aprox. 1,0 kWh/24 hours.

## Shutting your appliance down

If your appliance is to be shut down for any length of time, switch it off and disconnect the plug or switch off or unscrew the fuse.

Clean the appliance and leave the door open in order to prevent unpleasant smells.

The appliance complies with the relevant safety regulations and EC Directives 2004/108/EC and 2006/95/EC.

## Disclaimer

The manufacturer accepts no liability for any spoilage to the refrigerators content, not even when the device is within the warranty period. Similarly, the manufacturer accepts no liability for personal injury due to incorrectly stored goods, which are for personal consumption or re-sale.



## OPTIONAL ACCESSORIES FOR YOUR DX 500® - THOUGHT THROUGH TO THE END

Our accessories for the dry aging of  
half beef saddles and joints.



**DX0012**

### **STAINLESS STEEL HANGER**

Per Hanger 1/2 saddles up to a length  
of 50 cm possible.



**DX0025**

### **SHELVES**

perfect for individual joints



**DX0040**

### **LABELS FOR MEAT**

**(Set of 20)**

Including a nylon tie



**DX0058**

### **SALTAIR® HIMALAYA SALT BLOCK**

For a more intensive flavour



**DX0075**

### **SALTAIR® TRAY (STAINLESS STEEL) FOR THE BOTTOM**

mesh to the Salt Block-Set (DX0058)



**DX0090**

### **S-HOOK STAINLES STEEL**

Holds up to 100 kg (160 x 8 mm)



**DX0095**

### **SWIVEL HOOK STAINLESS STEEL**

Holds up to 100 kg (180 x 8 mm)



**DX0100**

### **UVC BULB**

**DX0110**

### **ACTIVE CARBON FILTER CARTRIDGE**

**COMING  
SOON**

**DX0081**

### **MOBILE PODIUM**

For perfect presentation at eye level.  
With useful drawer and trays.



Additional accessories, meat processing equipment  
and vacuum packing at: [www.dry-ager.com](http://www.dry-ager.com)



## THE DRY AGER MEAT SEMINARS

With Lucky Maurer and many other partners.

---

### **DRY AGED**

Learn about the manufacturing and refinement of the Dry Aging method. The interplay of temperature, humidity and technology.

### **B & C CUTS**

A beef cut is made up of more than three grades. We go in search of the so-called B & C cuts and also the premium cuts off the filet.

### **BUTCHERING OF A COMPLETE BACK SECTION**

A perfect back PORTION is dissected, as a German cut and as an Amicut. What exactly is Porterhouse, T-Bone and Cotes de Beauf - all is explained.

### **CROSSING DIFFERENT BREEDS AND COOKING TECHNIQUES**

Wagyu, Hereford, Angus, Chianina, etc. How do the different cattle breeds taste. In various degrees of maturity and preparation from Sous Vide to the 800 ° degree infra-red grill.

### **THE PERFECT GUIDE TO DRY AGED BEEF (SUPPLIES, TIPS & TRICKS)**

A small selection of recipes to accompany the perfect steak, barbecue, Chimichurri, salsa, mojo, BBQ sauces and more.

### **USEFUL INFORMATION OF EXOTIC BREEDS**

Get an insight into the breeding of the most exclusive cattle breed in the world and learn more about the breed, genetics, breeding, crossings and the owners of Wagyu & Black Angus.

---

FOR MORE INFORMATIONS  
[WWW.DRY-AGER.COM/SEMINARE](http://WWW.DRY-AGER.COM/SEMINARE)



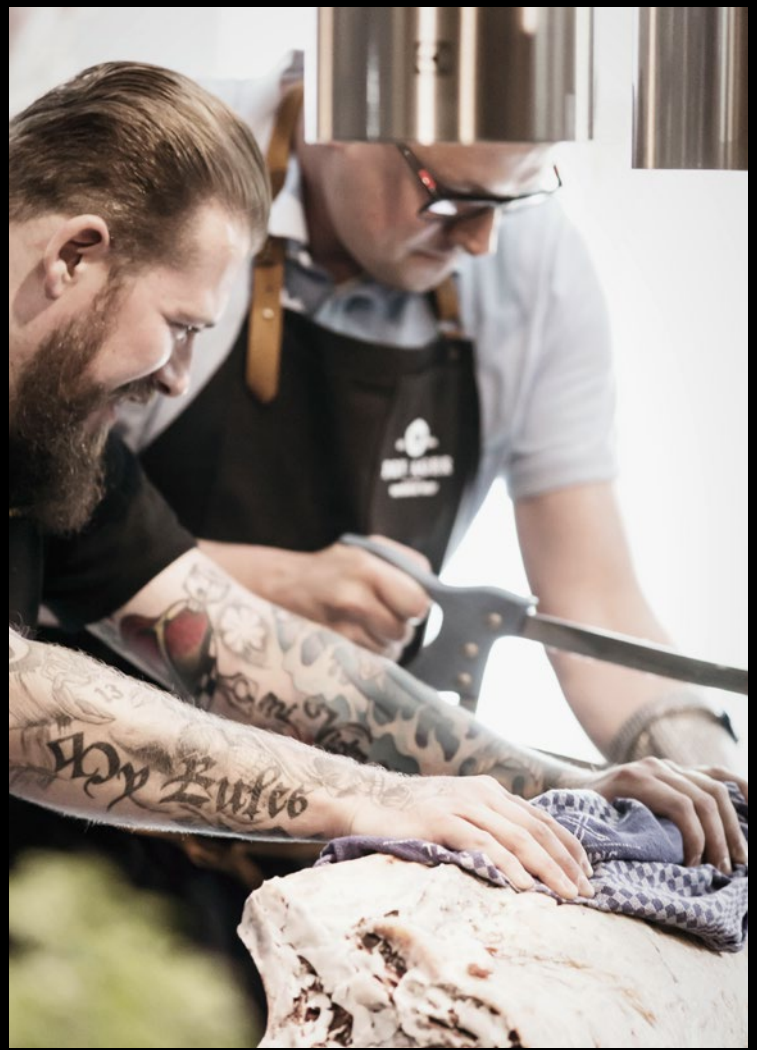



## You like the quality of your DRY AGER DX 500®?

Ask for more high-quality products and accessories from Landig & Lava – here a small overview:



Meat-Mincers



Sausage-Fillers



Electric Band  
Bone Saws



Sous-Vide  
Stirrers



Knife  
Sharpeners



Bone Saws



Slicing Machines



Sous-Vide Waterbaths



Cutting Board



Vacuum-Machines



Cleavers



Magnetic-Knife Holders



Knife Sharpeners



Gloves



Special Cleaner



Work Apron



Knife Sets



**Landig + Lava GmbH & Co. KG**

**DRY AGER Manufaktur**

Valentinstraße 35-1

D-88348 Bad Saulgau

Tel. (0049) 075 81/4 89 59-0

Fax (0049) 075 81/4 89 59-29

info@dry.ager.com | www.dry-ager.com

Version 02/2017